

L1204E CANE CRANE



Net Peak Power : 95 kW
Lift Capacity: 10 000 kg
Operating Weight : 24 309 kg
Full Turn Tipping Load: 6 093 kg

BELL

L1204E CANE CRANE

LIFTING SYSTEM

Two double acting, single stage cylinders	
Raise time	29 sec
Power down time	21 sec
Lift distance	7 827 m

LOAD CAPACITY

Rated Payload	10 000 kg (22 046 lbs)
---------------	------------------------

OPERATING WEIGHTS

Unladen	
Front	6 031 kg (13 296 lbs)
Rear	8 278 kg (18 249 lbs)
Total	14 309 kg (31 545 lbs)
Laden	
Front	1 833 kg (4 041 lbs)
Rear	22 476 kg (49 551 lbs)
Total	24 309 kg (53 592 lbs)

LINE DRAWINGS

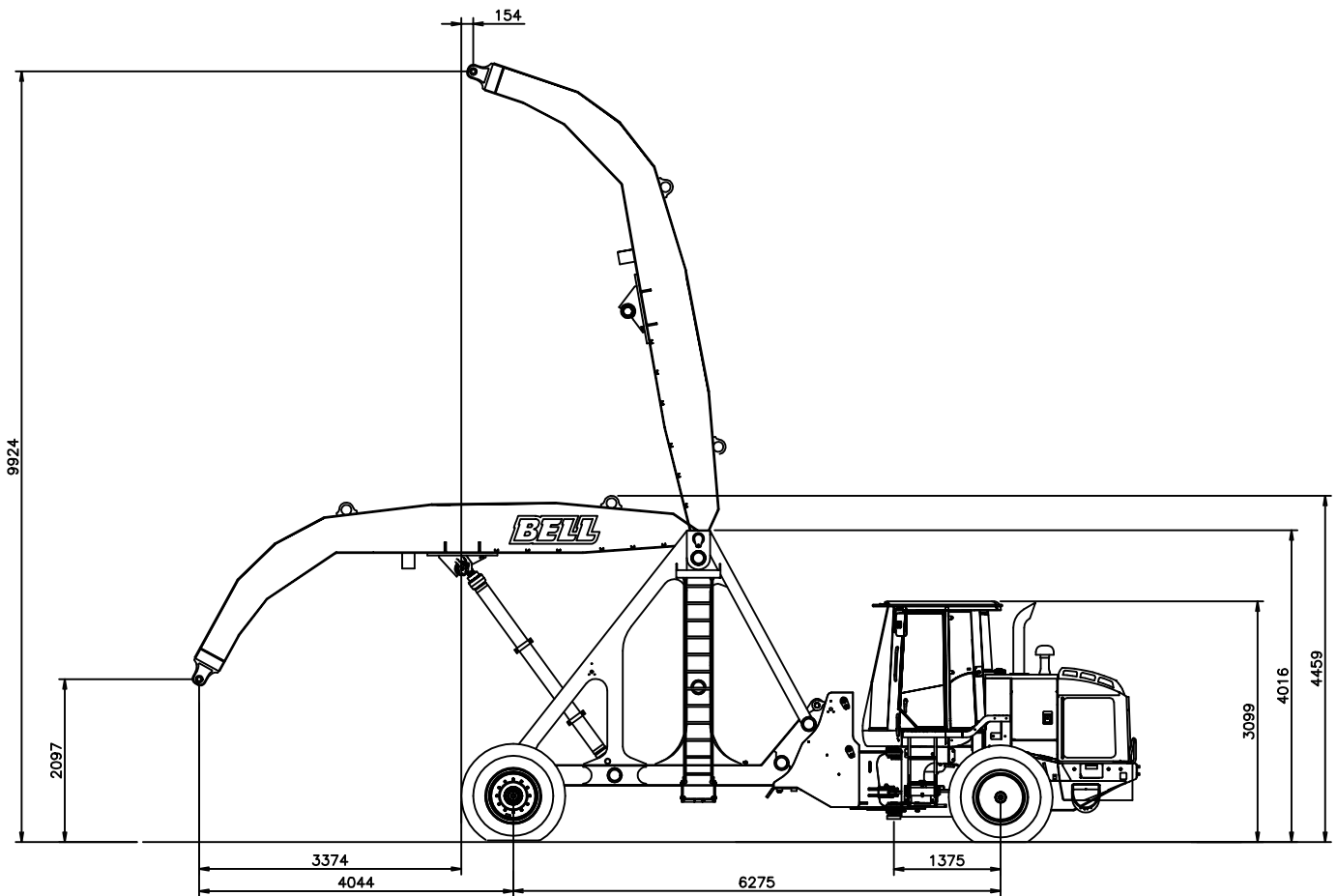

Telephone: +27 0 35 907 9431



Telephone: +49 6631 911 30



Telephone: +27 11 928 9700



Telephone: +34 918 796 019



Telephone: +33 555 89 23 56



Telephone: +44 1283 712 862

E-mail: sales@bellequipment.com • www.bellequipment.com

All dimensions are shown in millimetres, unless otherwise stated between brackets. Under our policy of continuous improvement, we reserve the right to change specifications and design without prior notice. Photographs featured in this brochure may include optional equipment.

Strong Reliable Machines
Strong Reliable Support

BELL