

B20D Fire Truck



- Gross Power: 170 kW (228 hp)
- Gross Torque: 810 Nm (597 lbft)

BELL

B20D Fire Truck

STANDARD EQUIPMENT

- 1.2 m Strobe light (Top of cab)
- Two tone siren
- Work light at back of machine
- 2 Warning beacons at rear of truck
- Equipment Lockers on top

OPTIONAL EQUIPMENT

- Flashing beacon
- Work lights
- Artic reverse light
- Electrical horn
- 12/24 volt emergency pump start part
- Teklite & mast + power supply
- Safety harness railing on top of tank

FIRE FIGHTING SYSTEM

Tank capacity	10 000 l
Water pump	KSB 2 stage centrifugal pump 2 000 l/min @ 10 bar

Water delivery	2 Female quick couplers ø 65 at rear
	2 Female quick couplers ø 65 at top
	1 Hose reel (60 m of 25 mm diameter hose)

Water Input	2 Male quick couplers ø 65
	1 4 Inch suction hose system (+ 9 m hose with strainer & foot valve)

OPERATING WEIGHTS

Unladen	Front	7 845 kg (17,295 lbs)
	Middle	3 550 kg (7,826 lbs)
	Rear	3 410 kg (7,518 lbs)
	Total	14 805 kg (32,639 lbs)
Laden	Front	8 390 kg (18,496 lbs)
	Middle	12 277 kg (27,066 lbs)
	Rear	12 138 kg (26,758 lbs)
	Total	32 805 kg (72,320 lbs)

LINE DRAWINGS

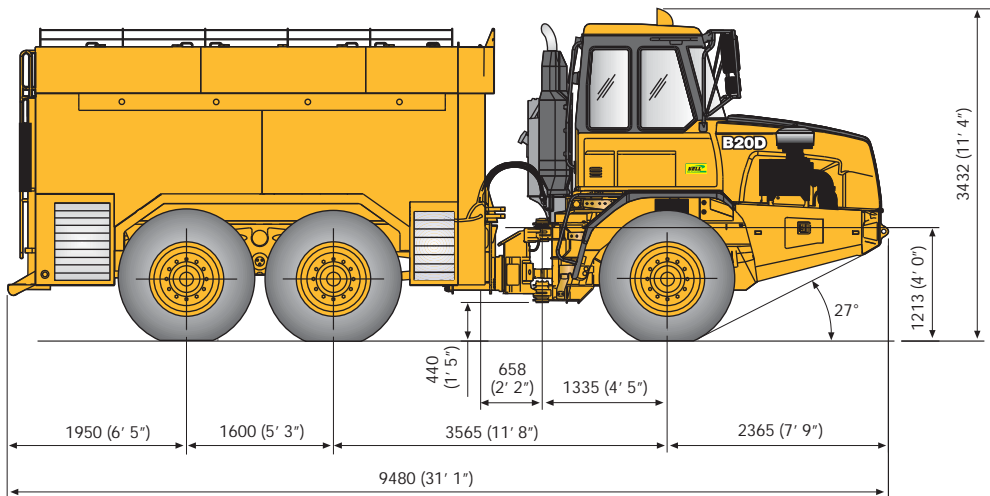

BELL SOUTH AFRICA : Tel: +27 (0)11-928 9700 • Fax: +27 (0)11-928 9702
 BELL INTERNATIONAL : Tel: +27 (0)35-907 9431 • Fax: +27 (0)35-797 4336
 E-mail: sales@bellequipment.com • www.bellequipment.com

All dimensions are shown in millimetres, unless otherwise stated between brackets. Under our policy of continuous improvement, we reserve the right to change specifications and design without prior notice. Photographs featured in this brochure may include optional equipment.

Strong Reliable Machines
Strong Reliable Support **BELL**