

ENGINE & ANCILLARIES

Yanmar TNV98

Configuration
4 cylinder

Aspiration
Naturally aspirated

Emission Level
Tier II

Governed Power
45 kW

Governed Speed
2 200 rpm

Displacement
3 319 cc

Fuel Filter Type
In-line water separator with separate spin on fuel filter.

Fuel Filter
5 µm

Coolant Capacity (Engine only)
4 litres

Radiator
Easy access and easy to clean. Agricultural spec fine dust tolerant - wide fin spacing.

Fuel Tank
Secure, lockable ground level filling. Integrated into lower section of the frame to keep a low centre of gravity.

Fuel Tank Capacity
100 litres

Air Cleaner Type
Radial Seal 2-stage primary and secondary filters, both fed by a self cleaning pre-cleaner. The system has a dash mounted restriction indicator.

HYDRAULIC SYSTEM

Hydrostatic Drive System
Servo controlled Variable displacement closed loop system.

Wheel Drive System
Robust, proven Bell planetary hub driven by high displacement radial piston motor with fail to safe spring applied hydraulically released multidisc wet brake.

Wheel Drive Make & Model
Bell #24P

Service Brake
Hydrostatic braking through the closed loop system.

Hydraulic Implement Pump 1
Maximum Flow at Engine
Rated Speed
60,9 l/min

Hydraulic Implement Pump 1
Maximum Intermittent Pressure
241 bar

Hydraulic Implement Pump 1
Use
Mast lift & lower

Hydraulic Implement Pump 2
Maximum Flow at Engine
Rated Speed
39,4 l/min

Hydraulic Implement Pump 2
Maximum Intermittent Pressure
280 bar

Hydraulic Implement Pump 2
Maximum Continuous Pressure
250 bar

Hydraulic Implement Pump 2
Use
Attachment - Grab open/close and tilt.

Tank
Integrated within the tubular frame

Tank Capacity
140 litres

Tank Breather
Remote to filler cap, 3 micron rating, 0.75 bar pressure.

Hydraulic Cooler Air Fin Spacing
Easy to clean wide fin spacing.

ELECTRICAL System

12 volt system with a single maintenance free battery mounted in the rear of the machine above the tail wheel.

Alternator Output
12 v 80 Amp

Starter Motor Rating
12 v 3,0 kW

Fuse Box
Blade fuses located inside the cabin in the instrumentation box.

Battery
Maintenance free gel filled battery 100 Amp Hour rating.

Battery Isolator
Single pole type with lock out mounted onto the right hand side of the frame.

Work Lights
8 lights in total. 4 Facing forwards, 2 facing rearwards, 1 facing side ways on each side of the frame.

Strobe Light
Mounted on the rear of frame

Interior lights
LED mounted inside the cab and inside the engine bay.

ESTIMATED OPERATING WEIGHTS WITH STANDARD OPTIONS

Unladen			
Front:			3 764 kg
Rear:			1 206 kg
Total:			4 970 kg
Laden			
Front:	5 529 kg	Boom In	5 784 kg
Rear:	533 kg	Boom Out	278 kg
Total:	6 062 kg		6 062 kg

Working Load Limit
1 100 kg

Tipping Load
1 210 kg

GRAB
0,36 m² grab

Note: Tyre sizes indicated represent available tyres at printing. Please ensure your choice is available at time of ordering.

- Lowest cost per tonne solutions
 - Low fuel consumption
 - Low maintenance
- Designed for field and zone loading operations
- Efficient and productive loading

I Dimensions

OPERATING POSITION

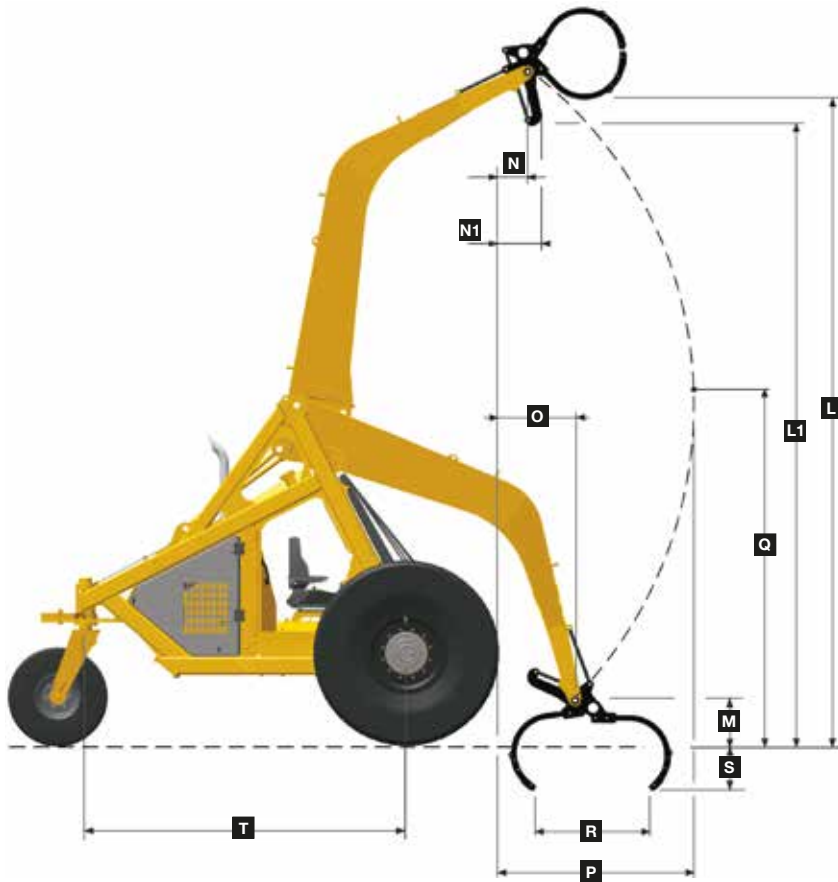

TRANSPORT POSITION

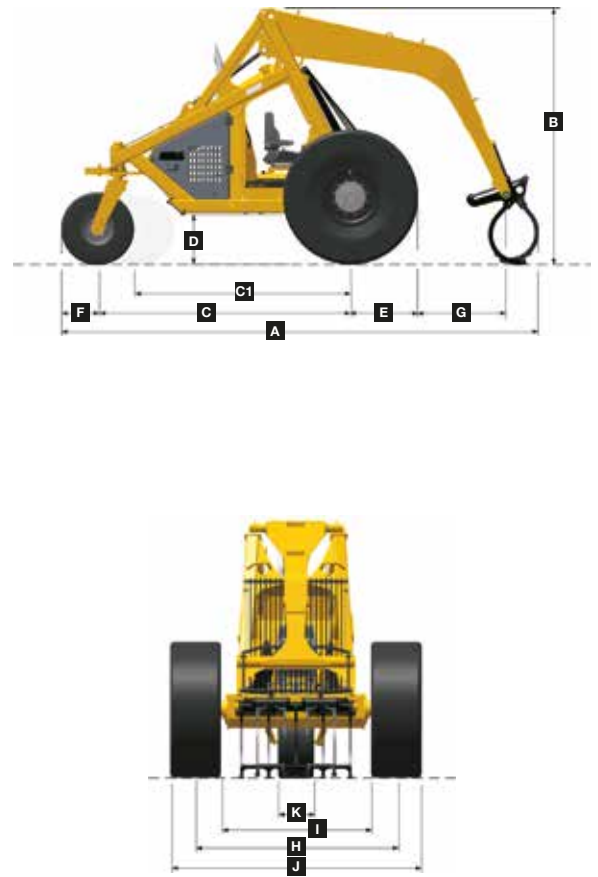

MACHINE DIMENSIONS

A	Length - Transport Position with Grab Closed	5 720 mm	I3	18.4/15 x 30 (option 2)	1 846 mm
B	Height - Transport Position with Grab Closed	3 064 mm	I4	18.4 x 34 (Option 3)	1 851 mm
C	Front Axle Centre to Tailwheel Axle Centre	3 030 mm	I5	18.4 x 26 (Option 4 Dual Wheelset)	1 687 mm
C1	Front Axle Centre to Tailwheel Axle Centre	2 546 mm	J	Width over Tyres - Front	
D	Ground Clearance - Front Axle Box	582 mm	J1	18.4 x 26 (Std Wheelset)	2 746 mm
E	Front Tyre - Free Radius (Free Diameter)		J2	23.1 x 26 (Option 1)	2 746 mm
E1	18.4 x 26 (Std Wheelset)	(ø1 458) 729 mm	J3	18.4/15 x 30 (Option 2)	2 778 mm
E2	23.1 x 26 (Option 1)	(ø1 458) 729 mm	J4	18.4 x 34 (Option 3)	2 787 mm
E3	18.4/15 x 30 (Option 2)	(ø1 549) 774.5 mm	J5	18.4 x 26 (Option 4 Dual Wheelset)	3 675 mm
E4	18.4 x 34 (Option 3)	(ø1 675) 837.5 mm	K	Tyre Width - Tailwheel	
E5	18.4 x 26 (Option 4 Dual Wheelset)	(ø1 458) 729 mm	K1	400 x 15.5 (Std Wheelset)	385 mm
F	Tailwheel - Free Radius (Free Diameter)		K2	18 x 15.5 (Option 1)	450 mm
F1	400 x 15.5 (Std Wheelset)	(ø864) 432 mm	L	Load Over Height - Cane Grab Tines	5 629 mm
F2	18 x 15.5 (Option 1)	(ø980) 490 mm	L1	Load Over Height	5 399 mm
G	Reach-Grab Pivot @ Ground Level	1 061 mm	M	Grab Pivot Height - Boom Down Position	406 mm
H	Track Width - Front		N	Reach - Grab Pivot - Boom Up Position	245 mm
H1	18.4 x 26 (Std Wheelset)	2 279.5 mm	N1	Reach - Grab Boom Up Position	368 mm
H2	23.1 x 26 (Option 1)	2 279.5 mm	O	Reach - Grab Pivot - Boom Down Position	665 mm
H3	18.4/15 x 30 (Option 2)	2 312 mm	P	Maximum Reach - Grab Pivot	1 768 mm
H4	18.4 x 34 (Option 3)	2 319 mm	Q	Height - Grab Pivot @ Maximum Reach	2 969 mm
H5	18.4 x 26 (Option 4 Dual Wheelset)	2 681 mm	R	Grab Open	972 mm
I	Inside Tyre Width - Front		S	Maximum Reach - Below Ground	379 mm
I1	18.4 x 26 (Std Wheelset)	1 813 mm	T	Front Axle Centre to Tailwheel Pivot Centre	2 788 mm
I2	23.1 x 26 (Option 1)	1 813 mm			

NOTE: All dimensions are unladen values based on the Standard Wheelsets U.O.N
 Negative(-) dimension value denotes position below ground level or behind front of wheel, whichever is applicable.

Grapple Dimensions & Operating Weights

Bell Grapple Dimensions Dimensions in millimeters U.O.N			
		Matriarch LX36	Matriarch LX42
A	Min. Closed Diameter	106	111
B	Grapple Open	1 630	1 783
C	Grapple Height - Open	823	893
D	Grapple Height - Tip to Tip	983	1 066
E	Grapple Closed	948	1 040
F	Grapple Height - Closed	625	669
G	Width Outer Tines	448	448
	Tip to Tip Area	0.36 m ²	0.42 m ²
	Weight - No Damper	222 kg	247 kg

Operating Weights		
	Working Load Limit	Tipping Load
225F Crank Logger	1 273 kg	1 400 kg
225F HP Tele Logger		
Boom In	1 568 kg	1 725 kg
Boom Out	1 051 kg	1 157 kg
125F Cane Loader	1 100 kg	1 210 kg
225F Forklift	3 500 kg	-

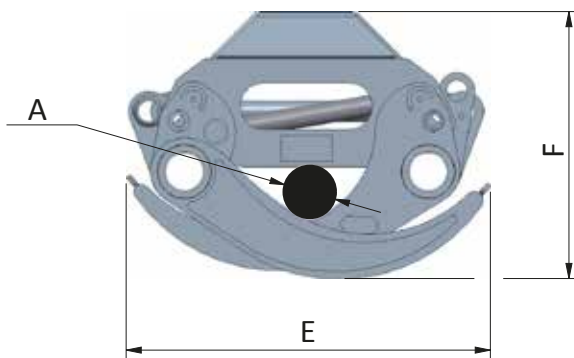

GRAPPLE CLOSED POSITION

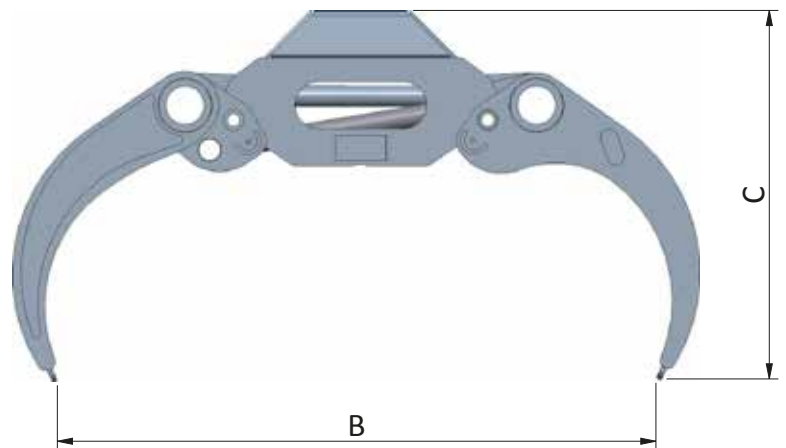

GRAPPLE OPEN POSITION

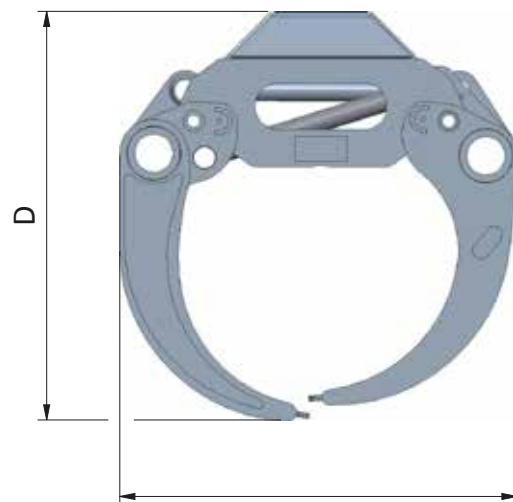

GRAPPLE TIP TO TIP POSITION

Cab Options



	225F Crank Logger	225F HP Tele Logger	125F Cane Loader	225F Forklift	CAB TRIM	Engine Doors	Cab Doors	Windscreen	Cab Door Glass	Roof Lining	Sound Kit >85dB	Air Conditioning
●	▲	●	▲		Basic option	✓	✗	✗	✗	✗	✗	✗
▲	▲	▲	●		Cab doors (no glazing)	✓	✓	✗	✗	✗	✗	✗
▲	▲	■	▲		Windscreen & wiper/washer	✓	✗	✓	✗	✗	✗	✗
▲	▲	■	▲		Windscreen & wiper/washer with cab doors (no glazing in doors)	✓	✓	✓	✗	✗		
▲	●	■	▲		Full Deluxe (full glazing)	✓	✓	✓	✓	✓	✓	✓

- STANDARD
- ▲ OPTION
- NOT AVAILABLE
- ✓ INCLUDED
- ✗ NOT INCLUDED

Features and Options

● STANDARD ▲ OPTION - NOT AVAILABLE

	225F Crank Logger	225F HP Tele Logger	125F Cane Loader	225F Forklift	
FRONT WHEELSETS					
●	▲	▲	▲	▲	460/85-30 T410
▲	▲	●	●	●	18.4 x 26 12 Ply
▲	▲	▲	-	-	Dual, 18.4 x 26 12 Ply
▲	●	-	-	-	23.1-26 T418FS
REAR WHEELSETS					
●	▲	●	▲	▲	400/60-15.5 T404
▲	●	▲	-	-	18.0 x 15.5 EcoAgri
-	-	-	●	●	400/60-15.5 BKT TR822 14Ply
SEAT					
●	▲	●	●	●	Unsuspending Lap Belt
▲	●	▲	▲	▲	Suspended
▲	▲	▲	▲	▲	Unsuspending 4 Point Harness
ATTACHMENT					
-	▲	-	-	-	Matriarch LX36
▲	●	-	-	-	Matriarch LX42
-	-	●	-	-	Cane Grab
-	-	-	●	●	Fork-lift with 1.2, Wide Carriage
-	-	-	▲	▲	Fork-lift with 2.5, Wide Carriage
-	-	-	POA	POA	Fork-lift with Brick Clamp
-	-	-	POA	POA	Fork-lift with Tyre Clamp
WORK LIGHTS					
●	●	●	●	●	Halogen Lights
▲	▲	▲	▲	▲	LED 1800L
▲	▲	▲	▲	▲	LED 3500L
BOOM					
-	-	●	-	-	Cane Boom
●	▲	-	-	-	Crank Boom
▲	●	-	-	-	Tele Boom
▲	▲	-	-	-	Ext Tele Boom
COUNTER WEIGHT					
▲	▲	●	▲	▲	1 Weight
●	▲	▲	▲	▲	4 Weights
▲	●	▲	▲	▲	6 Weights
▲	▲	▲	●	▲	7 Weights
MISCELLANEOUS					
●	▲	●	●	●	Rear View Side Mirrors <i>(Note: not available if Log Rest Option is selected)</i>
▲	▲	-	▲	▲	Door Proximity Switches
▲	●	-	-	-	Log Rest
▲	▲	▲	▲	▲	Fire Extinguisher Bracket

	225F Crank Logger	225F HP Tele Logger	125F Cane Loader	225F Forklift	
WARNING LIGHTS/INSTRUMENTATION					
●	●	●	●	●	Hydraulic charge filter bypass
●	●	●	●	●	Engine oil pressure
●	●	●	●	●	Engine coolant temperature high
●	●	●	●	●	Hydraulic oil temperature high
●	●	●	●	●	Air cleaner blocked
●	●	●	●	●	Low fuel
●	●	●	●	●	Battery charge
●	●	●	●	●	Cold start
●	●	●	●	●	Park brake active
▲	▲	▲	▲	▲	Reverse Camera
▲	▲	▲	▲	▲	Fleetm@tic®
SWITCHES					
●	●	●	●	●	Ignition (key)
●	●	●	●	●	Hour metre
●	●	●	●	●	Park brake
●	●	●	●	●	Horn
●	●	●	●	●	Interior lights
●	●	●	●	●	Cold start aid
●	●	●	●	●	Battery isolator
SENSORS					
●	●	●	●	●	Low fuel level
▲	▲	▲	▲	▲	Door open proximity switch (if doors are fitted)
●	●	●	●	●	Air cleaner blocked
●	●	●	●	●	Hydraulic charge filter bypass
●	●	●	●	●	Engine oil pressure
●	●	●	●	●	Engine coolant temp
●	●	●	●	●	Hydraulic oil temperature
▲	▲	▲	▲	▲	Reverse alarm
CAB (see page 15 for details)					
●	▲	●	▲	▲	Basic option
▲	▲	▲	●	▲	Cab doors (no glazing)
▲	▲	-	▲	▲	Windscreen and wiper/washer
▲	▲	-	▲	▲	Windscreen and wiper/washer with cab doors (no glazing in doors)
▲	●	-	▲	▲	Full deluxe (full glazing)
LANGUAGE					
●	▲	●	●	●	English
▲	▲	▲	▲	▲	French
▲	●	▲	▲	▲	Spanish

Please note that all information supplied in this brochure is intended to assist the customer in understanding the general applications of Bell Equipment's F-series machines.

Performance information is intended for estimating purposes only. Due to the many variables unique to individual operations such as weather, terrain, ground conditions, operator productivity, etc neither Bell Equipment Company nor its Dealers warrant that the machines described will perform as estimated.

Due to Bell Equipment's policy of constant product improvement, specifications are subject to change without notice.

BELL INTERNATIONAL: Tel: +27 (0)35 907 9431

E-mail: marketing@bellequipment.com Web: www.bellequipment.com



Tel: +61 (0)8 9355 2442



Tel: +49 (0)663 191 130



Tel: +27 (0)11 928 9700



Tel: +44 (0)1283 712 862



Tel: +33 (0)5 55 892 356



Tel: +7 495 287 80 02



Tel: (704) 655 2802

• H881F12 • H882F12 • H883F12 • H884F12

**Strong Reliable Machines
Strong Reliable Support**

BELL