

UITECO6

4WD Sugarcane Slew Loader





The complete package



Innovative design and the world's best components work to deliver a built-for-purpose machine, well suited to controlled traffic operations, with the reliability and efficiency customers expect from Bell Equipment.



A new level of comfort

Innovative slewing cab + boom dramatically reduces operator fatigue. Added luxury features and a snug fitting rubber floor mat for easy cleaning.

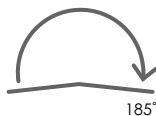

185° Slew angle



Radio



Cupholder



Suspension seat



Maintenance made simple



- Safe and convenient ground level servicing and daily checks
- The condenser conveniently slides out of the way for easier cooler cleaning
- Centrally positioned grease points on the boom enable access while keeping both feet on the ground
- Steering, push piler and grab share a common cylinder



Lowest cost per tonne

4 Wheel drive delivers better traction in poor underfoot conditions, high travel speed reduces travel time while the infinitely adjustable push-piler is suited to any field condition. Combined they provide unmatched productivity. The 'find centre' feature on the slew automatically returns the crane to its starting position to further aid productivity.

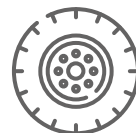

4 wheel drive system



26 km/h travel speed



Unrivalled safety



- Slip proof step and handrails/grabs
- 9 x Perfectly positioned LED lights are indispensable for 24-hour operations
- Large rearview mirrors
- Sturdy steel windscreen guard
- Machine mass optimised for stability vs ground pressure - better for soft ground conditions



UITECO6 4WD Sugarcane Slew Loader

ENGINE

JCB Diesel Max 444 T2 NA
63 kW (84 HP) @ 2 200 rpm

Peak torque: 320 Nm (236 lb-ft) @ 1 200 rpm

4,4 litre, 4-Cylinder, direct injection

Mechanical engine - equipped with a dry element filtration system with secondary safety element.

Onboard electronic engine protection system

Fuel tank capacity: 100 litres

DRIVE SYSTEM

Hydrostatic drive system

Variable displacement wheel drives

4 Wheel drive

Maximum speed of 26 kph (16.2 mph)

Cross-axle difflock

AXLES AND TYRES

Rigid front axle

Oscillating rear axle with steering hubs

Rear axle steer

Tyre size - front	23.1-26
- front alternate	18.4-30
- rear	14.9-24

CRANE & GRAB

Double acting - boom & dipper arm

Boom slew travel: 185°

Grab capacity
Narrow axles: 0.38 m²
Wide axles: 0.42 m²

Grab arrangement - dangle type, fore/aft pivoting.

Push piler - infinitely adjustable tine positioning, hydraulic height adjustment.

HYDRAULIC SYSTEM

Load sensing variable piston pump

Low effort CANbus operator controls

Hydraulic tank capacity: 100 litres

End-of-stroke damping on slew, boom & arm joints.

ELECTRICAL SYSTEM

Single 12 volt battery

Alternator: 14 volt, 95 amp

LED worklights, reverse alarm & hooter

LED tail lights, incorporating indicators and brake light.

BRAKES

Hydrostatic dynamic braking system.

Spring applied, hydraulic release park brake
- two drive wheels

OPERATOR STATION

Superior visibility - operator always faces the load.

Machine systems monitoring and warning indicators.

Ergonomic operator controls
- mini-coordinate joystick (selectable control pattern)

Glazed operator cab

Air-conditioner, HVAC

Radio with FM and bluetooth option

Suspension seat option

DIMENSIONS AND WEIGHT

Narrow axles: 2.1 m (18.4-30 Front wheelset)
2.3 m (18.4-30 Front wheelset)
2.5 m (18.4-30 Front wheelset)

Wide axles: 3.0 m (18.4-30 Front wheelset)
3.0 m (23.1-26 Front wheelset)
3.2 m (18.4-30 Front wheelset)
3.4 m (18.4-30 Front wheelset)
3.4 m (23.1-26 Front wheelset)

Operating weight: 7 159 kg

TRANSPORT DIMENSIONS

Length: 6 240 mm

Height: 3 600 mm

Width: Varies, according to option choice

Dimensions

SIDE VIEW

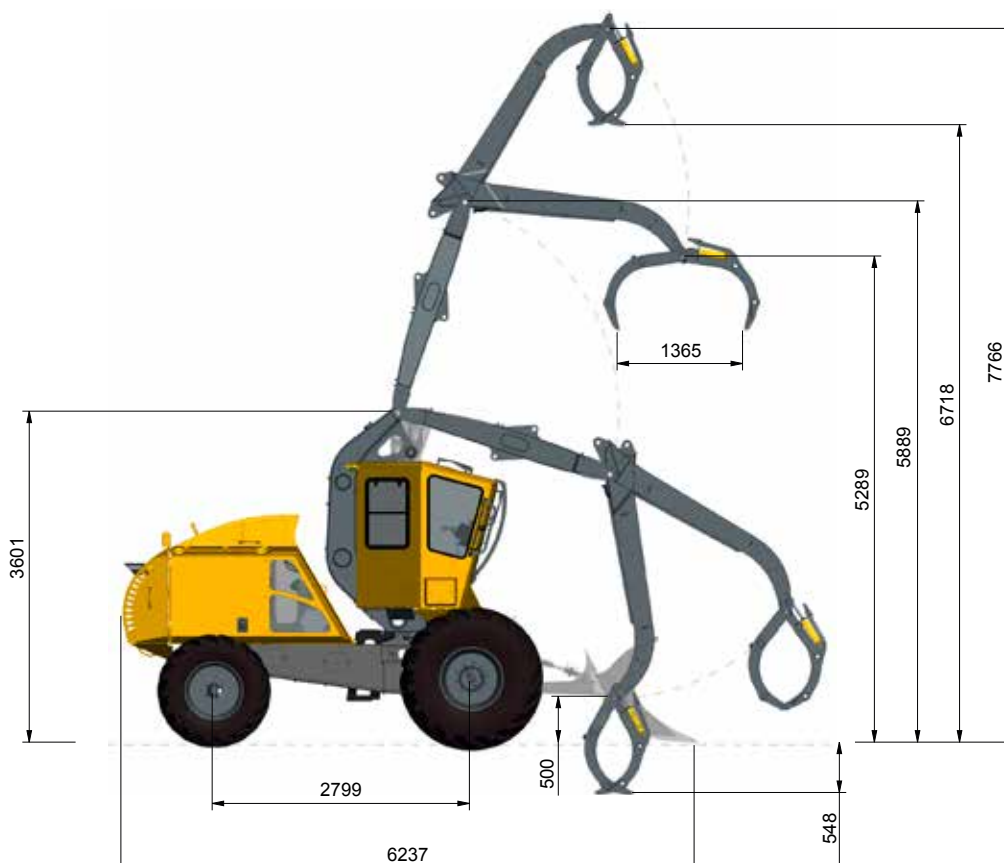

UiteCO6 4WD Sugarcane Slew Loader

SIDE VIEW



TOP VIEW

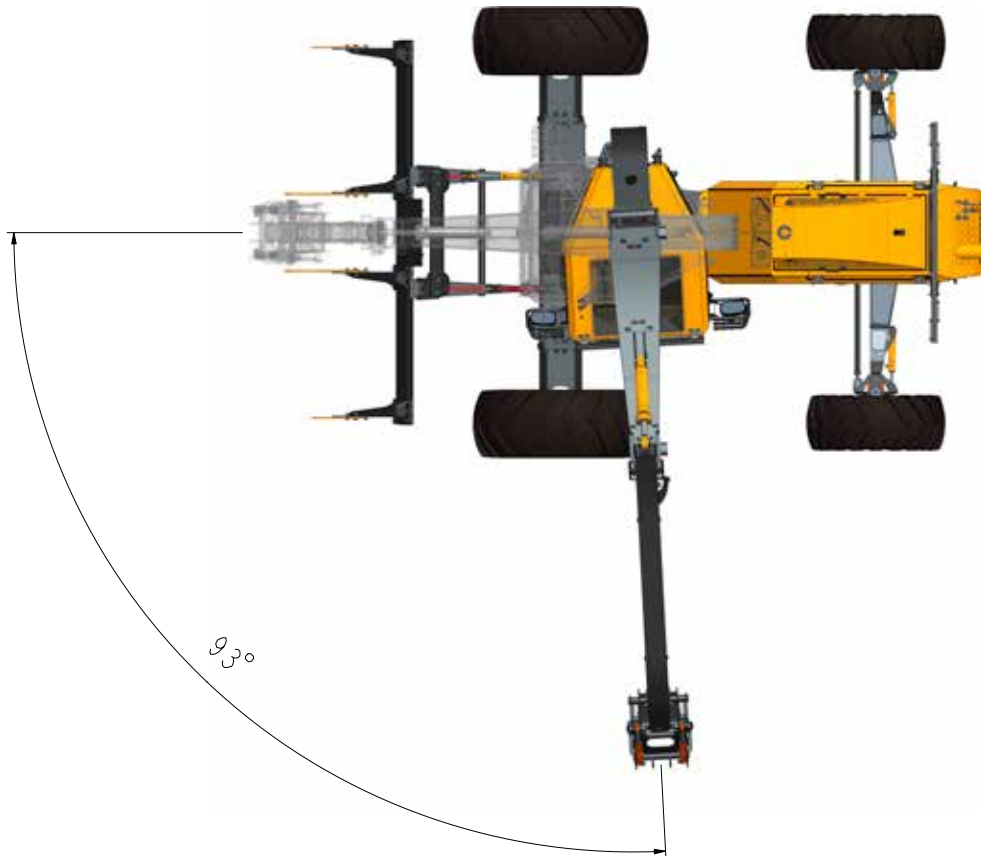

All dimensions are shown in millimeters, unless otherwise stated between brackets. Under our policy of continuous improvement, we reserve the right to change technical data and design without prior notice. Photographs featured in this brochure may include optional equipment.

BELL INTERNATIONAL: Tel: +27 (0)35-907 9431

E-mail: marketing@bellequipment.com

Web: www.bellequipment.com



Tel: +61 (0)8 9355 2442

Tel: +49 (0)6631 / 91 13 0

Tel: +27 (0)11 928 9700



Tel: +33 (0)5 55 89 23 56

Tel: +44 (0)1283 712862

Tel: +1 (704) 655 2802