

## ENGINE & ANCILLARIES

Yanmar TNV98T

**Configuration**  
4 cylinder

**Aspiration**  
Turbo Charged

**Emission Level**  
Tier II

**Governed Power**  
57 kW

**Governed Speed**  
2 200 rpm

**Displacement**  
3 319 cc

**Fuel Filter Type**  
In-line water separator with separate spin on fuel filter.

**Fuel Filter**  
5 µm

**Coolant Capacity (Engine only)**  
4 litres

**Radiator**  
Easy access and easy to clean. Agricultural spec fine dust tolerant - wide fin spacing.

**Fuel Tank**  
Secure, lockable ground level filling. Integrated into lower section of the frame to keep a low centre of gravity.

**Fuel Tank Capacity**  
100 litres

**Air Cleaner Type**  
Radial Seal 2-stage primary and secondary filters, both fed by a self cleaning pre-cleaner. The system has a dash mounted restriction indicator.

## HYDRAULIC SYSTEM

**Hydrostatic Drive System**  
Servo controlled Variable displacement closed loop system.

**Wheel Drive System**  
Robust, proven Bell planetary hub driven by high displacement radial piston motor with fail to safe spring applied hydraulically released multidisc wet brake.

**Wheel Drive Make & Model**  
Bell #29P

**Service Brake**  
Hydrostatic braking through the closed loop system.

**Hydraulic Implement Pump 1**  
**Maximum Flow at Engine**  
**Rated Speed**  
60,9 l/min

**Hydraulic Implement Pump 1**  
**Maximum Intermittent Pressure**  
241 bar

**Hydraulic Implement Pump 1**  
**Use**  
Boom lift & lower

**Hydraulic Implement Pump 2**  
**Maximum Flow at Engine**  
**Rated Speed**  
39,4 l/min

**Hydraulic Implement Pump 2**  
**Maximum Intermittent Pressure**  
280 bar

**Hydraulic Implement Pump 2**  
**Maximum Continuous Pressure**  
250 bar

**Hydraulic Implement Pump 2**  
**Use**  
Attachment - Grapple Open/Close, Tele Ext in/out and Rotator.

**Tank**  
Integrated within the tubular frame

**Tank Capacity**  
140 litres

**Tank Breather**  
Remote to filler cap, 3 micron rating, 0.75 bar pressure.

**Hydraulic Cooler Air Fin Spacing**  
Easy to clean wide fin spacing

**ELECTRICAL**  
**System**  
12 volt system with a single maintenance free battery mounted in the rear of the machine above the tail wheel.

**Alternator Output**  
12 v 80 Amp

**Starter Motor Rating**  
12 v 3,0 kW

**Fuse Box**  
Blade fuses located inside the cabin in the instrumentation box.

**Battery**  
Maintenance free gel filled battery 100 Amp Hour rating.

**Battery Isolator**  
Single pole type with lock out mounted onto the right hand side of the frame.

**Work Lights**  
8 lights in total. 4 Facing forwards, 2 facing rearwards, 1 facing side ways on each side of the frame.

**Strobe Light**  
Mounted on the rear of frame

**Interior lights**  
LED mounted inside the cab and inside the engine bay.

## ESTIMATED OPERATING WEIGHTS WITH STANDARD OPTIONS

Unladen		
Front:		4 309 kg
Rear:		1 656 kg
Total:		5 965 kg
Laden	Boom In	Boom Out
Front:	6 562 kg	6 293 kg
Rear:	955 kg	712 kg
Total:	7 517 kg	7 005 kg

**Working Load Limit**  
1 568 kg 1 051 kg

**Tipping Load**  
1 725 kg 1 157 kg

## GRAPPLE

Bell LX42  
(Bell LX36 as an option)

Note: Tyre sizes indicated represent available tyres at printing. Please ensure your choice is available at time of ordering.

- Low capital outlay
- Low operating cost due to few working parts
- Low fuel consumption
- Simple to maintain
- Multi-purpose unit
- Highly manoeuvrable

## I Dimensions

### OPERATING POSITION

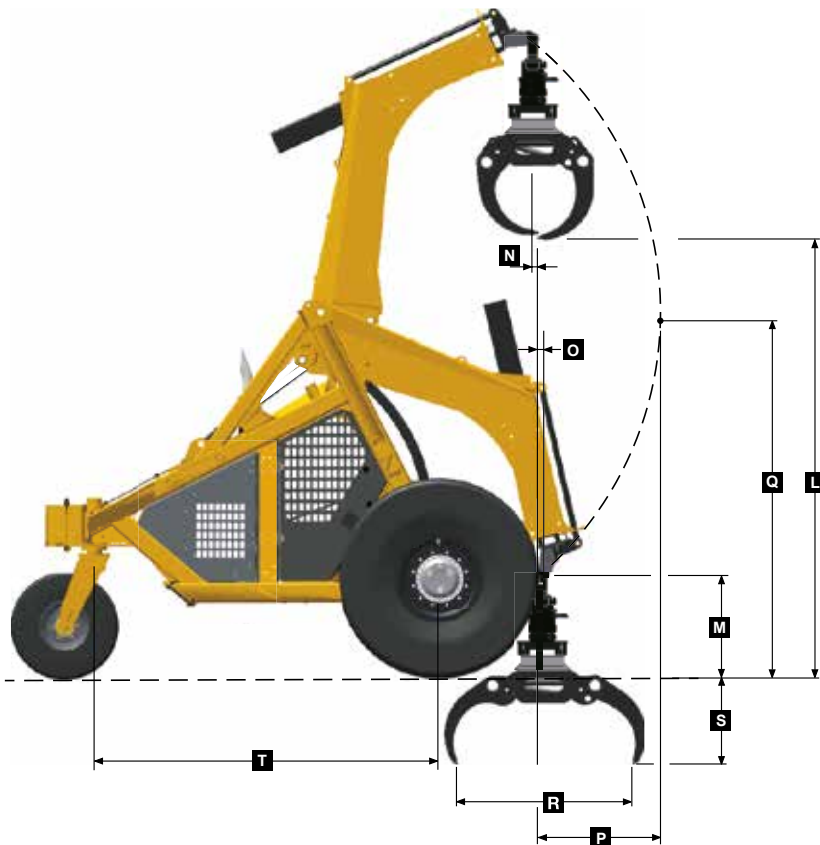

### TRANSPORT POSITION

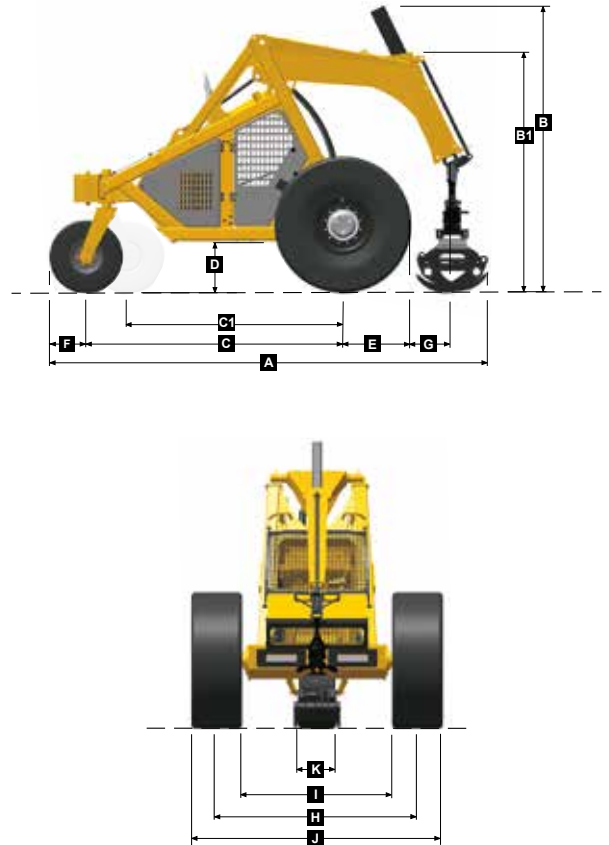

### MACHINE DIMENSIONS

A	Length - Transport - LX36 Grapple Closed, Teleboom Retracted	5 175 mm	I3	18.4/15 x 30 (Option 2)	1 846 mm
A	Length - Transport - LX36 Grapple Closed, Teleboom Extended	6 232 mm	I4	18.4 x 34 (Option 3)	1 851 mm
A	Length - Transport - LX42 Grapple Closed, Teleboom Retracted	5 331 mm	I5	18.4 x 26 (Option 4-Dual Wheelset)	1 687 mm
A	Length - Transport - LX42 Grapple Closed, Teleboom Extended	6 363 mm	J	Width over Tyres-Front	
B	Height - Transport - LX36 Grapple Closed, Teleboom Retracted	3 397 mm	J1	23.1 x 26 (Std Wheelset)	2 982 mm
B1	Height - Transport - LX36 Grapple Closed, Teleboom Extended	3 367 mm	J2	18.4 x 26 (Option 1)	2 746 mm
B	Height - Transport - LX42 Grapple Closed, Teleboom Retracted	3 468 mm	J3	18.4/15 x 30 (Option 2)	2 778 mm
B1	Height - Transport - LX42 Grapple Closed, Teleboom Extended	3 426 mm	J4	18.4 x 34 (Option 3)	2 787 mm
C	Front Axle Centre to Tailwheel Axle Centre	3 030 mm	J5	18.4 x 26 (Option 4-Dual Wheelset)	3 675 mm
C1	Front Axle Centre to Tailwheel Axle Centre	2 546 mm	K	Tyre Width - Tailwheel	
D	Ground Clearance - Front Axle Box	578 mm	K1	400 x 15.5 (Std Wheelset)	385 mm
E	Front Tyre - Free Radius (Free Diameter)		K2	18 x 15.5 (Option 1)	450 mm
E1	23.1 x 26 (Std Wheelset)	807,5 mm (Ø1 615)	L	Load Over Height - LX36 Grapple, Teleboom Retracted	3 547 mm
E2	18.4 x 26 (Option 1)	729 mm (Ø1 458)	L	Load Over Height - LX36 Grapple, Teleboom Extended	3 955 mm
E3	18.4/15 x 30 (Option 2)	774,5 mm (Ø1 549)	L	Load Over Height - LX42 Grapple, Teleboom Retracted	3 441 mm
E4	18.4 x 34 (Option 3)	837,5 mm (Ø1 675)	L	Load Over Height - LX42 Grapple, Teleboom Extended	3 849 mm
E5	18.4 x 26 (Option 4-Dual Wheelset)	729 mm (Ø1 458)	M	Grapple Pivot Height - Boom Down Position, Teleboom Retracted	816 mm
F	Tailwheel - Free Radius (Free Diameter)		M	Grapple Pivot Height - Boom Down Position, Teleboom Extended	142 mm
F1	400 x 15.5 (Std Wheelset)	432 mm (Ø864)	N	Reach-Grapple Pivot - Boom Up Position, Teleboom Retracted	27 mm
F2	18 x 15.5 (Option 1)	490 mm (Ø980)	N	Reach-Grapple Pivot - Boom Up Position, Teleboom Extended	866 mm
G	Reach - Grapple Pivot @ Ground Level - LX36, Teleboom Retracted	481 mm	O	Reach-Grapple Pivot - Boom Down Position, Teleboom Retracted	39 mm
G	Reach - Grapple Pivot @ Ground Level - LX36, Teleboom Extended	1 538 mm	O	Reach-Grapple Pivot - Boom Down Position, Teleboom Extended	255 mm
G	Reach - Grapple Pivot @ Ground Level - LX42, Teleboom Retracted	561 mm	P	Maximum Reach - Grapple Pivot, Teleboom Retracted	1 042 mm
G	Reach - Grapple Pivot @ Ground Level - LX42, Teleboom Extended	1 593 mm	P	Maximum Reach - Grapple Pivot, Teleboom Extended	1 942 mm
H	Track Width - Front		Q	Height - Grapple Pivot @ Maximum Reach, Teleboom Retracted	2 964 mm
H1	23.1 x 26 (Std Wheelset)	2 382 mm	Q	Height - Grapple Pivot @ Maximum Reach, Teleboom Extended	2 964 mm
H2	18.4 x 26 (Option 1)	2 279,5 mm	R	LX36 Grapple Open	1 414 mm
H3	18.4/15 x 30 (Option 2)	2 312 mm	R	LX42 Grapple Open	1 577 mm
H4	18.4 x 34 (Option 3)	2 319 mm	S	Maximum Reach - Below Ground - LX36 Grapple, Teleboom Retracted	714 mm
H5	18.4 x 26 (Option 4-Dual Wheelset)	2 681 mm	S	Maximum Reach - Below Ground - LX36 Grapple, Teleboom Extended	1 672 mm
I	Inside Tyre Width - Front		S	Maximum Reach - Below Ground - LX42 Grapple, Teleboom Retracted	768 mm
I1	23.1 x 26 (Std Wheelset)	1 782 mm	S	Maximum Reach - Below Ground - LX42 Grapple, Teleboom Extended	1 725 mm
I2	18.4 x 26 (Option 1)	1 813 mm	T	Front Axle Centre to Tailwheel Pivot Centre	2 788 mm

NOTE: Please refer to 225F for Crank option dimensions.

All dimensions are Unladen values based on the Standard Wheelsets and Grapple U.O.N.

Negative (-) dimension value denotes position below ground level or behind front of wheel, whichever is applicable.