

ULTeco5

Sugarcane Slew Loader

Where Durability, Functionality & Efficiency Meet



SIDE VIEW

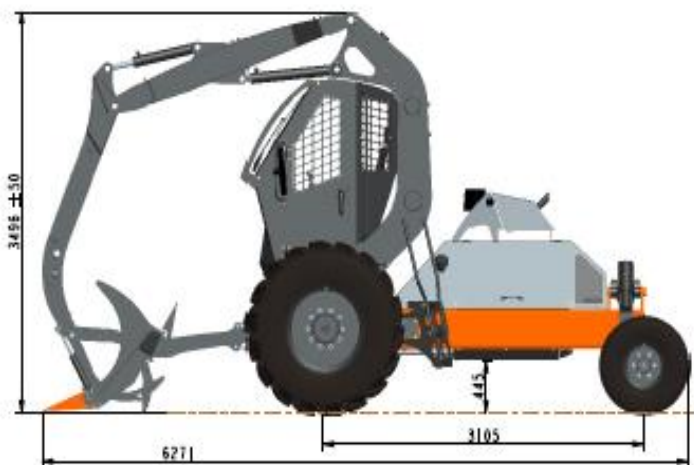

FRONT VIEW

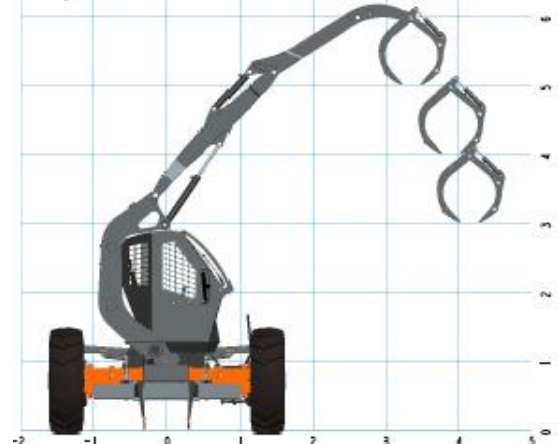

ENGINE		
JCB Diesel Max 444 T2 NA 63 kW (84 HP) @ 2200 RPM		
Mechanical Engine - Equipped with a dry element filtration system with secondary safety element and filter mounted visual warning indicator - Precleaner, Primary Filter and Secondary Safety Element.		
Fuel Tank Capacity - 100 litres		
DRIVE SYSTEM		
Hydrostatic Drive System		
Single Speed		
Two Wheel Drive		
Maximum Speed of 11 KPH (6.9 MPH)		
AXLES AND TYRES		
Rigid Front Axle		
Oscillating Rear Axle with Castering Wheels		
Differential Steering System		
Tyre Size - Front	Opt 1	18.4 - 30
Tyre Size - Front	Opt 2	16.9 - 34
Tyre Size - Rear		400/60 - 15.5
BOOM AND GRAPPLE		
Double Acting - Boom & Dipper Arm		
Boom Slew Travel - 185 degree		
Wide Grapple with Tilting Function		
Grapple Capacity - 0.38 sqm		
OPTIONAL PUSH-PILER & GRAPPLE		
Push Piler - Infinitely Adjustable Tine Positioning, Hydraulic Height Adjustment		
Grapple Arrangement - Dangle Type, Fore/Aft Pivoting		
HYDRAULIC SYSTEM		
Tandem Gear Pump		
Split Control Valve - Optimal Flow Sharing		
Low Effort Pilot Operated Controls		
Hydraulic Tank Capacity - 100 litres		
ELECTRICAL SYSTEM		
Single 12 Volt Battery		
Alternator - 14 volt 95 amp		
Worklights, Reverse Alarm & Hooter		
OPERATOR STATION		
Superior Visibility - Operator Always Faces the Load		
Machine Systems Monitoring and Warning Indicators		
Ergonomic Operator Controls - Joystick Type		
Glazed Operator Windshield		
Fully Adjustable Operator Seat		
BRAKES		
Hydrostatic Dynamic Braking System		
Spring Applied, Hydraulic Release Park Brake - Two Drive Wheels		
WEIGHTS AND DIMENSIONS		
Track Width - Standard*		2.74 m
Track Width - Optional		2.20m
Track Width - Optional		2.10m
Operating Weight		5900 kg

*Rotate Rim to Increase Track Width to 3.00 m

**Alternate Track Width Options Available Upon Request

