

STATIC DIMENSIONS

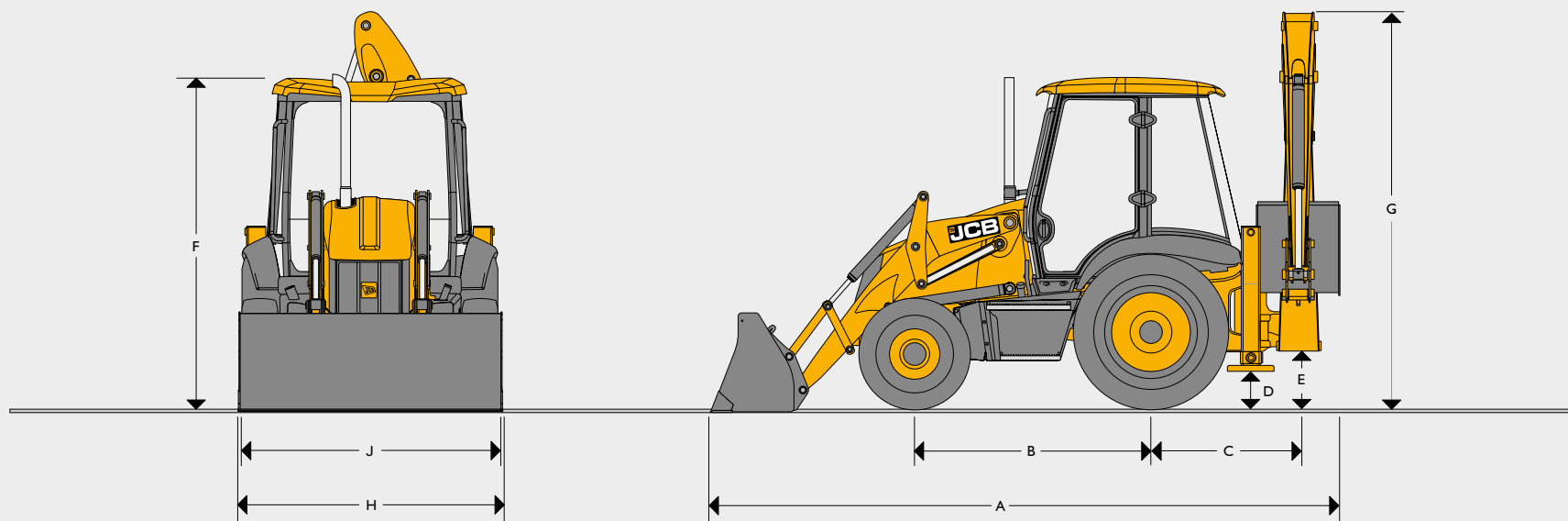

		3DX ECO	3DX PLUS	3DX PRO
A	Total travel length	m	5.90	5.90
B	Wheelbase	m	2.17	2.17
C	Slew centre to rear axle centre	m	1.32	1.32
D	Minimum ground clearance (stabiliser foot clearance)	m	0.36	0.36
E	Slew ground clearance	m	0.51	0.53
F	Cab roof height	m	2.87	2.87
G	Total travel clearance	m	3.61	3.61
H	Shovel width	m	2.23 (6-in-1 shovel) / 2.35 (GP shovel)	2.23 (6-in-1 shovel)
J	Rear frame width	m	2.24	2.24

EXCAVATOR/LOADER PERFORMANCE

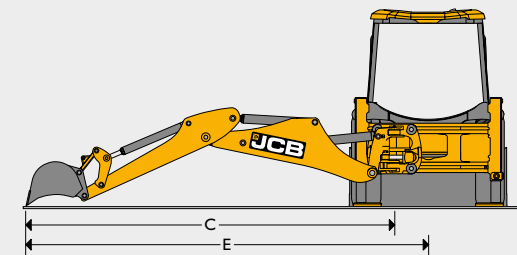
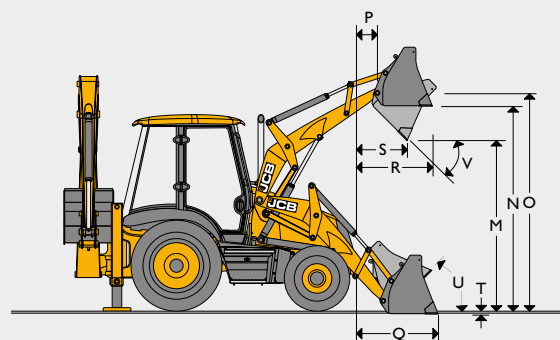
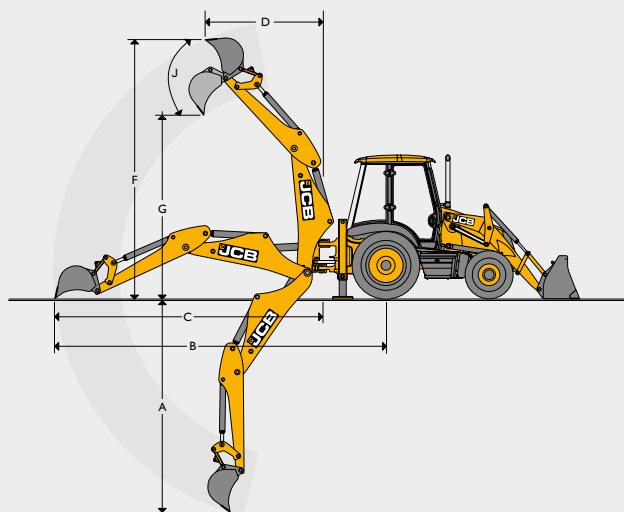

Excavator performance		3DX ECO	3DX PLUS	3DX PRO
A	Max dig depth	m	4.77	4.77
B	Reach-ground level to rear wheel centre	m	6.72	6.72
C	Reach-ground level to slew centre	m	5.40	5.40
D	Reach at full height to slew centre	m	2.74	2.74
E	Side reach to centre line of machine	m	6.02	6.02
F	Max. working height	m	5.97	5.97
G	Max. load over height	m	4.18	4.18
J	Bucket rotation – power	degrees	185°	185°
	Bucket tearout force	kgf	5700	5700
	Dipper tearout force	kgf	3010	3010
	Lift capacity to bucket pivot	kg	1490	1490
Loader performance				
M	Dump height	m	2.74	2.74
N	Load over height	m	3.32	3.32
O	Pin height	m	3.38	3.38
P	Pin forward reach	m	0.43	0.43
Q	Reach at ground	m	1.43	1.43
R	Max. reach at full height	m	1.25	1.25
S	Reach at full height – bucket dumped	m	0.89	0.89
T	Below ground level dig depth	m	0.06	0.06
U	Rollback at ground	degrees	44°	44°
V	Dump angle	degrees	38°	38°
	Shovel breakout force	kgf	6219 (GP shovel) 6010 (6-in-1 shovel)	6010
	Loader arm breakout force	kgf	5300	5300
	Shovel capacity		1.0m <sup>3</sup> (6-in-1 shovel) / 1.1m <sup>3</sup> (GP shovel)	1.0m <sup>3</sup> (6-in-1 shovel)
	Lift capacity to full height	kg	3495	3495

ENGINE	3DX ECO	3DX PLUS	3DX PRO*
Model	JCB 448, 4 cylinder, water cooled, diesel, naturally aspirated	JCB 444, Turbocharged, 4 cylinder, water cooled, diesel	JCB 444, Turbocharged, 4 cylinder, water cooled, diesel
No. of cylinders	4	4	4
Displacement	4.8 litres	4.4 litres	4.4 litres
Gross power	56kW (76 hp) @ 2200rpm	68.6 kW (92hp) @ 2200rpm	68.6 kW (92hp) @ 2200rpm
Max torque	305Nm @ 1100rpm	408Nm @ 1200rpm	408Nm @ 1200rpm

\*Auto stop automatically shuts off the engine when idle after 6 minutes, saving on wear and tear and also reducing fuel usage.

Auto idle reduces fuel consumption and unnecessary wear and tear by automatically reducing engine rpm to low idle after 10 seconds if no hydraulic services are active.

ECO/Power mode limits hand throttle speed to 1500rpm to reduce fuel consumption by up to 10%. Plus mode allows engine speed to be increased to 2200rpm to increase productivity by up to 8%.

SERVICE CAPACITIES		3DX ECO		3DX PLUS, 3DX PRO
		2WD	4WD	4WD
Cooling system	ltr	17.5	17.5	20
Fuel tank	ltr	128	128	128
Engine oil with filter	ltr	15	15	20
Gearbox with filter	ltr	20	20	20
Rear axle	ltr	20	20	20
Front axle	ltr	-	20	20
Hydraulic system incl. tank	ltr	130	130	92

### TRANSMISSION

JCB Synchro-shuttle transmission: It provides superb drive power in all conditions. It consists of a 4-speed, full synchromesh gearbox with integral torque convertor and electrically operated reversing power shuttle.

- Easy-to-use, column mounted electric reversing shuttle which can change machine direction while allowing operator to keep hands on the steering wheel leading to fast cycle times.
- The pedal layout and conventional 4-pattern gear lever with transmission disconnect switch adds to the overall ease of operation. On-the-move gear changes are possible.
- Torque convertor stall ratio is 3.01:1 (2WD), 2.52:1 (4WD).

JCB EasyShift (3DX PRO): Ease of operation for better productivity with effortless gear shift.

- Easy to use, low effort column mounted electric gear change.
- On-the-move gear changes are possible.
- Semi automatic kick down on loader lever. While loading in second gear, operator can shift to first gear with push of a button, and automatically shift to second gear as soon as reverse gear is engaged.
- Gear indicator shown digitally on front display console.

	3DX ECO (2WD)	3DX ECO (4WD)	3DX PLUS	3DX PRO
Manufacturer	JCB	JCB	JCB	JCB
Type	Synchroshuttle	Synchroshuttle	Synchroshuttle	EasyShift
Gears forward/reverse	4 forward/2 reverse	4 forward/2 reverse	4 forward/2 reverse	4 forward/2 reverse
Shuttle control – F/R	Power shuttle	Power shuttle	Power shuttle	Power shuttle
<b>Travel speeds*</b>	<b>kph</b>	<b>kph</b>	<b>kph</b>	<b>kph</b>
Gear 1	4.5	5.7	5.7	5.7
Gear 2	7.3	11.7	11.7	9.2
Gear 3	15.4	22.0	22.0	19.8
Gear 4	32.3	40.0	40.0	40.0

\*Speeds may vary dependant on tyre selection.

**TURNING CIRCLE**

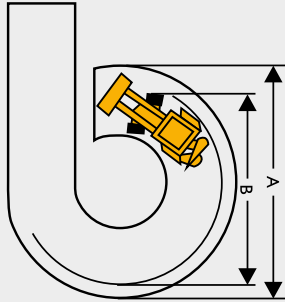

\* Standard bucket in travel position

**Inner wheels braked**

	2WD	4WD
A Outside loader bucket	4.32m	4.89m
B Outside wheels	3.10m	3.60m

**Inner wheels not braked**

A Outside loader bucket	5.71m	5.45m
B Outside wheels	4.47m	4.16m

<b>STEERING</b>	Front wheel full power hydrostatic system utilising the main hydraulic pump via a steering priority valve. In the event of engine failure, emergency steering is maintained (all models).			
<b>BRAKES</b>	<p><b>Service:</b> Hydraulically actuated dual line, self adjusting, oil immersed, multi-disc type on the rear axle, well protected from dirt, water etc. requiring no maintenance.</p> <p><b>Parking:</b> Hand operated, disc brake on rear axle input disc.</p> <p><b>Brake pedal:</b> Two independently operable foot pedals enable machine to manoeuvre in tight spaces. Pedals are linked together for normal use.</p> <p><b>2WD / 4WD:</b> Electrical selection between 2WD / 4WD allows on-the-move changes.</p>			
<b>CAB</b>	Fully adjustable seat and soft touch steering wheel • 'Walk through' two door access • Seat belt, large convex rear view mirror, interior light front screen wiper, horn, hazard warning system, tool box • Instrumentation panel includes engine speed, engine hours, speedometer, fuel level, water temperature gauge and 12v connection • Audible and visual fault warning system for alternator charge, coolant temperature, engine oil pressure, blocked air filter, transmission oil pressure and temperature, and hand brake on • Air conditioning standard on 3DX PLUS and PRO.			
<b>AXLES</b>	<p><b>Rear:</b> Drive axle rigidly mounted, incorporates JCB Max-Trac torque proportioning differential, driven by short propshaft from gear box.</p> <p><b>Front:</b> 4WD, Steer axle, centrally pivoted with oscillation angle of 16°.</p>			
<b>ELECTRICAL AND INSTRUMENTATION</b>	<p>12 volt negative ground, utilising wiring and connectors meeting IP69 water ingress test standard. Central fuse panel.</p> <p>LiveLink standard on all models • Bluetooth radio standard • Guide me home lights switches on the external lights for 30 seconds to assist operator to walk safely after parking machine.</p> <p><b>Battery:</b> 130 A/hr, 900 CCA. <b>Alternator:</b> 90 amp standard. <b>Front working lights:</b> 2 fixed. <b>Rear working lights:</b> 2 fixed and 2 adjustable</p> <p>3DX PRO additional standard features: LED lights • 6 x roof mounted air vents.</p>			
<b>TYRES (TUBED TYPE)</b>	<p><b>2WD</b></p> <p><b>Front:</b> 9x16-16 ply</p> <p><b>Rear:</b> 16.9x28-12 ply</p>	<p><b>4WD</b></p> <p><b>Front:</b> 12.5x18-12 ply</p> <p><b>Rear:</b> 16.9x28-12 ply</p>		
<b>WEIGHT</b>	<p><b>Operating:</b> 3DX ECO (2WD): 7660kg</p> <p>3DX PLUS/PRO: 7800kg</p>			
<b>HYDRAULIC SYSTEM</b>	<p>JCB vari-matic hydraulics • Main relief valve: 228bar • Unloader valve: 207bar • Filtration through suction strainer and return line JCB Filtermatic filter • During excavation the circuit automatically varies hydraulic power to match digging conditions for extra performance, control and power • Careful routing of hydraulic hoses and pipework guards against site damage and allows easy servicing • JCB diagonal (X) pattern controls.</p> <p>3DX PRO has Servo controls (SAE pattern) as standard and Smooth Ride System (SRS) reducing material spillage and bounce during travel by damping out forces imposed on the machine and loader arms.</p>			
		<b>3DX ECO</b>	<b>3DX PLUS</b>	<b>3DX PRO</b>
Pump		Gear	Gear	Variable flow piston
Flow (lpm)		108	123	125
Pressure (bar)		228	228	270