

Felling Heads

Technical Data

↔ DIMENSIONS	MT50FH	MT50FHF
Height [mm]	1 170	1 816
Width [mm]	1 372	1 162
Depth [mm]	1 170	1 359



WEIGHT

Gross [kg]	535	955
------------	-----	-----



GRAPPLE

Area [sqm]	0,25	0,25
Maximum jaw open [mm]	890	890
Minimum jaw closed [mm]	50	50
Lateral tilt		30°



SAW

Hultdins SuperCut		
Saw chain type	0,404	404
Saw bar [mm]	750	750
Saw motor [cm ³ /rev]	19	19
Maximum cut diameter [mm]	530	530



HYDRAULICS

Pressure rating [bar]	200-280	200-280
Oil flow minimum [Lpm]	65	65
Oil flow maximum [Lpm]	1 05	1 05



ROTATOR MODEL

Indexator GV124S - Grapple		
Saw rotator		
Rotation [degrees]	360	
Weight [kg]	59	



BASE MACHINE (CARRIER SIZE)

Excavator minimum weight [t]	13	13
Excavator maximum weight [t]	21	21

Line Drawings

MT50FH

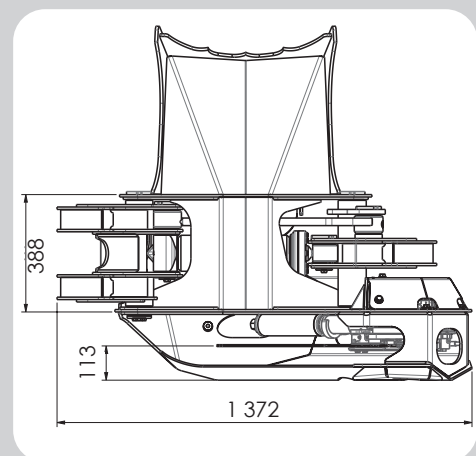
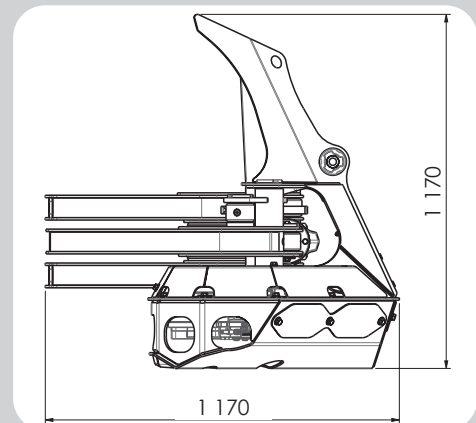

MT50FHF

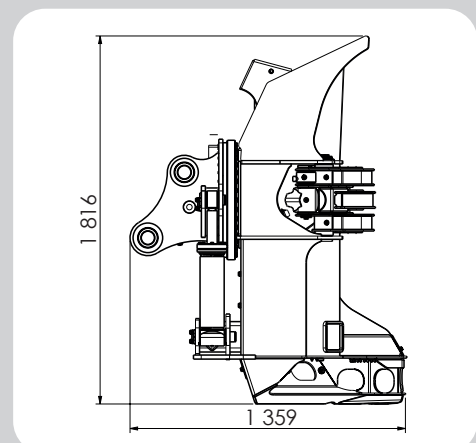
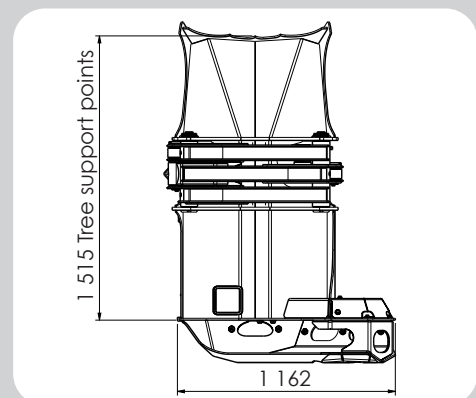

| Features**MT50FH****Rotator**

Provided by an industry-leading supplier, the rotator is ideally matched to the grapple for efficient operation.

Pins

Chrome plated pins provide maximum life and limited wear to the bushes. In addition, non-swivel pins ensure minimal wear to the serviceable bushes.

Body

Designed to be low in weight and high in strength, the body ensures a long-lasting head structure.

Saw

The saw is the proven Hultdins SuperCut with a 750mm saw bar.

Tines

Wear resistant grapple tines ensure a solid stem grip.

30° Lateral tilt adapter

Turns 30° in both directions.

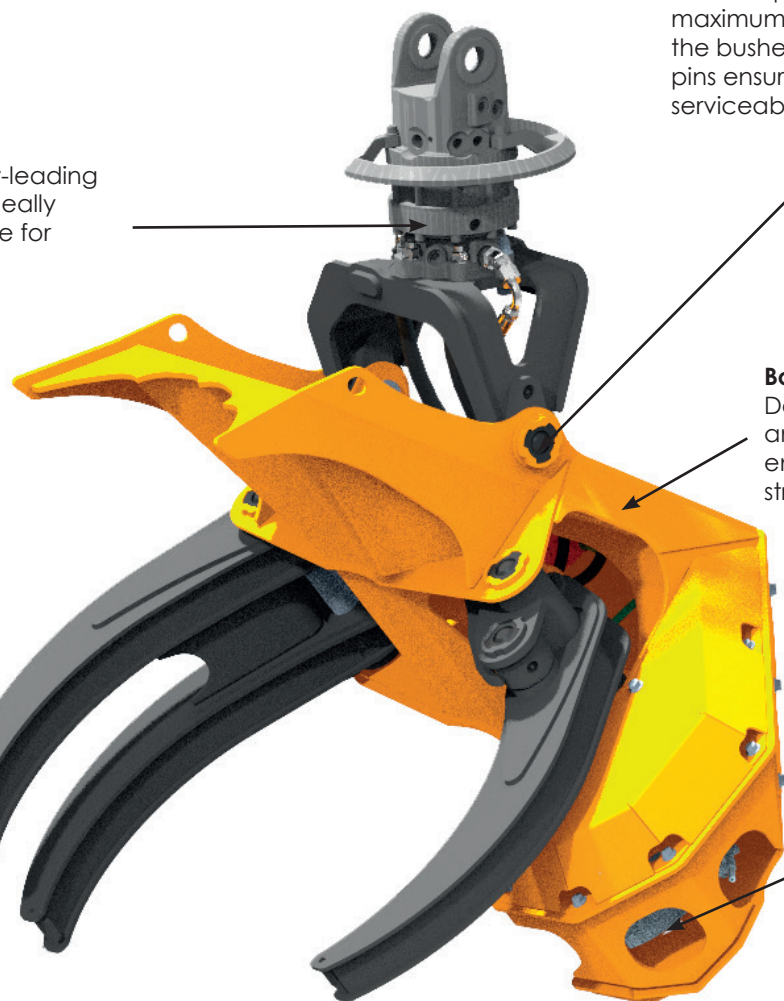
**MT50FHF**