

Pickaroons

Technical Data

DIMENSIONS

Width [mm]	1 022
Height [mm]	1 502

SHANK

Gross [mm]	80
------------	----

BASE MACHINE (CARRIER SIZE)

Excavator maximum weight [t]	21
------------------------------	----

Line Drawings

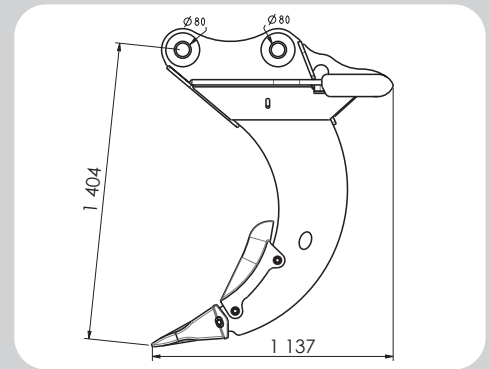
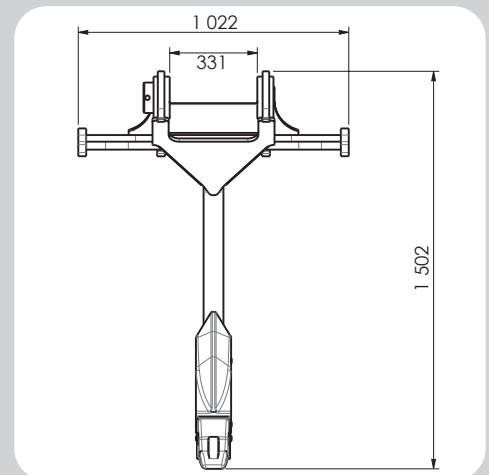

Cross-Cut Grapples

Technical Data

DIMENSIONS

Length 'A' [mm]	1 095
Width 'B' [mm]	162
Height 'C' [mm]	400
Width 'D' [mm]	120
Saw bar [cm]	90

WEIGHT

Gross [kg]	102
------------	-----

HYDRAULIC SYSTEM

Saw motor displacement [cm ³]	10
Minimum hydraulic pressure, saw motor [bar*]	160
Minimum hydraulic flow, saw motor [lpm *]	65
Hydraulic pressure, saw bar feed out [bar]	50 - 55
Hydraulic pressure, chain tensioning [bar]	30
Gas pressure, accumulator [bar]	1
Air pressure, saw bar retraction [bar]	12 - 14

* Maximum saw chain speed and Maximum power input to the saw chain may NEVER exceed recommendations from each saw chain manufacturer.

CHAIN LUBRICATION

Type of lubrication	Proportional
Lube oil tank capacity [L]	3,0

Line Drawings

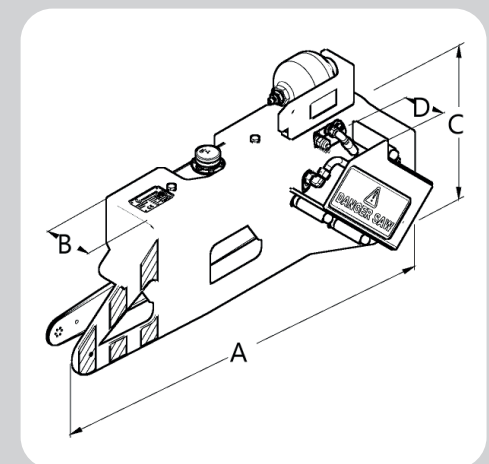

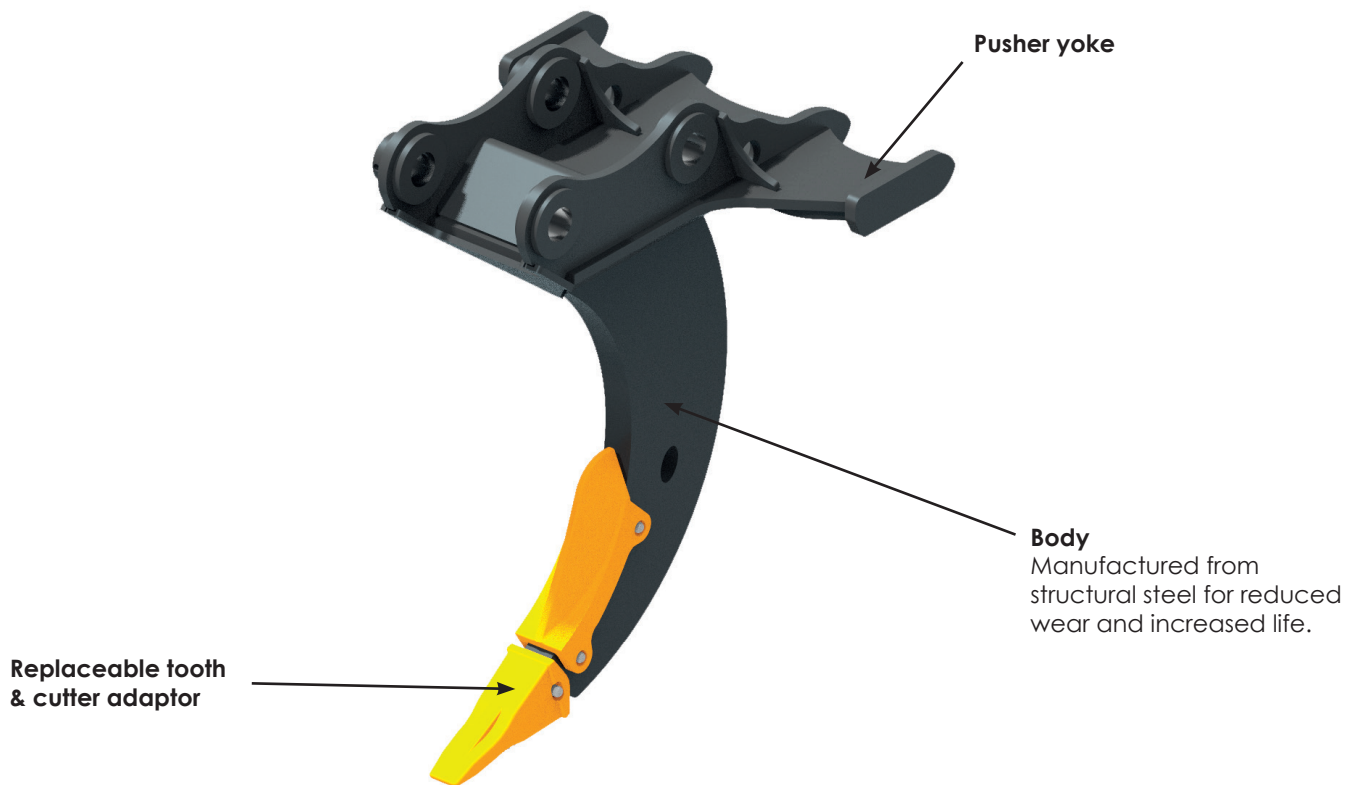
| Features**| Features**