

# B20E Articulated Dump Truck

## ENGINE

**Manufacturer**  
Mercedes Benz

**Model**  
OM924LA

**Configuration**  
Inline 4, turbocharged and intercooled.

**Maximum Net Power**  
160 kW (214 hp) @ 2 200 rpm in accordance with UN ECE R120

**Gross Torque**  
810 Nm (597 lbft)  
@ 1 200 -1 600 rpm

**Displacement**  
4,80 litres (293 cu.in)

**Auxiliary Brake**  
Exhaust Valve Brake  
Engine Valve Brake

**Fuel Tank Capacity**  
195 litres (53 US gal)

**Certification**  
OM924LA meets Euro III emissions regulations

## TRANSMISSION

**Manufacturer**  
Allison

**Model**  
Standard Non Retarder:  
3000P ORS  
Optional Retarder: 3000PR ORS

**Configuration**  
Fully automatic planetary transmission with integral retarder.

**Layout**  
Engine mounted

**Gear layout**  
Constant meshing planetary gears, clutch operated

**Gears**  
6 Forward, 1 Reverse

**Clutch Type**  
Hydraulically operated multi-disc

**Control Type**  
Electronic

**Torque Control**  
Hydrodynamic with lock-up in all gears

## TRANSFER CASE

**Manufacturer**  
Kessler

**Series**  
W1400

**Layout**  
Remote mounted

**Gear Layout**  
Three in-line helical gears

**Output Differential**  
Interaxle 33/67 proportional differential. Automatic inter-axle differential lock.

## AXLES

**Manufacturer**  
Bell

**Model**  
15T

**Differential**  
High input limited slip differential with spiral bevel gears.

**Final Drive**  
Outboard heavy duty planetary on all axles

## BRAKING SYSTEM

**Service Brake**  
Dual circuit, full hydraulic actuation dry disc brakes with 8 calipers.

Maximum brake force:  
244 kN (54 720 lbf)

**Park & Emergency**  
Spring applied, air released driveline mounted disc.

Maximum brake force:  
182 kN (40 802 lbf)

**Auxiliary Brake**  
Automatic exhaust valve brake and engine valve brake. Optional automatic, adjustable, integral, hydrodynamic transmission retarder. Output shaft speed dependant.

**Total Retardation Power**  
Continuous non-retarder:  
99 kW (133 hp).  
Continuous retarder:  
144 kW (193 hp).  
Maximum non-retarder:  
99 kW (133 hp).  
Maximum retarder:  
505 kW (677 hp).

## WHEELS

**Type**  
Radial Earthmover

**Tyre**  
20.5 R 25

## FRONT SUSPENSION

Semi-independent, leading A-frame supported by hydro-pneumatic suspension struts.

## REAR SUSPENSION

Pivoting walking beams with laminated rubber suspension blocks

## HYDRAULIC SYSTEM

Full load sensing system serving the prioritized steering, body tipping and brake functions. A ground-driven, load sensing emergency steering pump is integrated into the main system.

**Pump Type**  
Variable displacement load sensing piston

**Flow**  
202 L/min (53 gal/min)

**Pressure**  
310 Bar (4 500 psi)

**Filter**  
5 microns

## STEERING SYSTEM

Double-acting cylinders with ground driven emergency steering pump.

**Lock to lock turns**  
4,5

**Steering Angle**  
45°

## DUMPING SYSTEM

Two double-acting, single stage, dump cylinders

**Raise Time**  
8,5 s

**Lowering Time**  
7 s

**Tipping Angle**  
70° standard, or any lower angle programmable

## PNEUMATIC SYSTEM

Air drier with heater and integral unloader valve, serving park brake and auxiliary functions.

**System Pressure**  
8,1 Bar (117 psi)

## ELECTRICAL SYSTEM

**Voltage**  
24 V

**Battery Type**  
Two AGM (Absorption Glass Mat) type

**Battery Capacity**  
2 X 75 Ah

**Alternator Rating**  
28 V 80 A

## VEHICLE SPEEDS

1st	11 km/h	7 mph
2nd	20 km/h	12 mph
3rd	27 km/h	17 mph
4th	38 km/h	24 mph
5th	50 km/h	31 mph
6th	50 km/h	31 mph
R	7 km/h	4 mph

## CAB

ROPS/FOPS certified

## Load Capacity & Ground Pressure

OPERATING WEIGHTS			GROUND PRESSURE		LOAD CAPACITY		OPTION WEIGHTS		
UNLADEN*		LADEN*		LADEN		BODY	m <sup>3</sup> (yd <sup>3</sup> )	kg (lb)	
Tare kg (lb)**		ISO 6016 kg		(No sinkage or		Struck Capacity	9 (11)	Bin liner	477 (1 052)
Front	7 970 (17 575)	(lb)***		Total Contact Area)		SAE 2:1 Capacity	11 (14,5)		
Middle	3 941 (8 690)	Front	9 770 (21 544)	20.5 R 25	kPa (Psi)	SAE 1:1 Capacity	13,5 (17,5)	EXTRA WHEELSET	
Rear	3 531 (7 786)	Middle	11 931 (26 308)	Front	236 (34,2)	Rated Payload	18 000 kg	20.5 R 25	
Total	15 443 (34 051)	Rear	11 741 (25 889)	Middle	311 (45,1)			(per vehicle) Add	222 (489,4)
	ISO 6016 kg (lb)***	Total	33 443 (73 741)	Rear	311 (45,1)		(39 690 lbs)		
Front	7 985 (17 607)								
Middle	4 042 (8 913)								
Rear	3 632 (8 008)								
Total	15 659 (34 528)								

\* Includes additional mass. \*\* No fuel, no operator. \*\*\* Full fuel and operator

## Dimensions

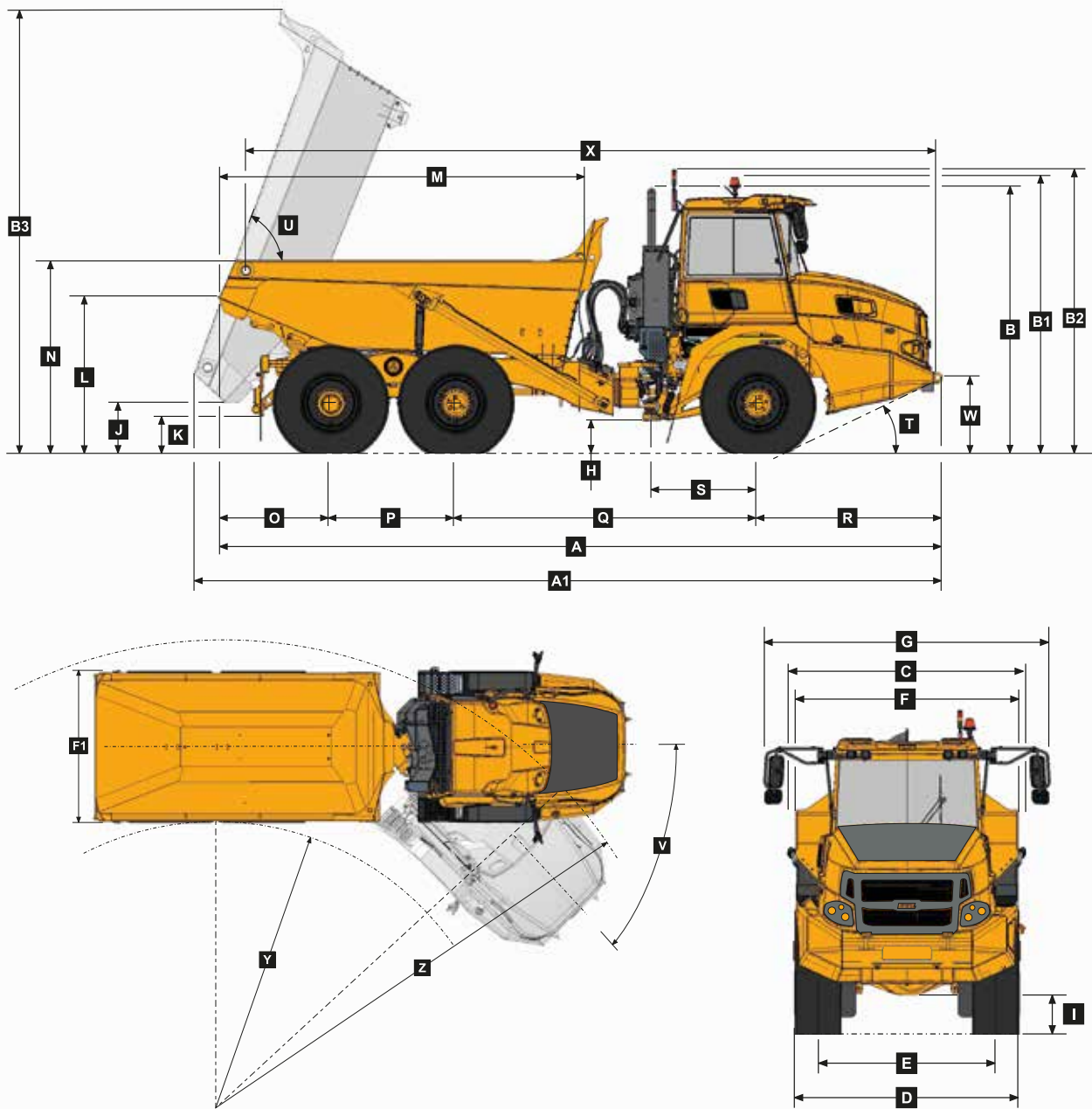

### Machine Dimensions

A	Length - Transport Position	9 271 mm (30 ft. 5 in.)	L	Bin Lip Height - Transport Position	2 060 mm (6 ft. 9 in.)
A1	Length - Bin Fully Tipped	9 573 mm (31 ft. 5 in.)	M	Bin Length	4 709 mm (15 ft. 5 in.)
B	Height - Transport Position	3 454 mm (11 ft. 4 in.)	N	Load over Height	2 533 mm (8 ft. 3 in.)
B1	Height - Rotating Beacon	3 595 mm (12 ft.)	O	Rear Axle Centre to Bin Rear	1 449 mm (4 ft. 9 in.)
B2	Height - Load Light	3 689 mm (12 ft. 1 in.)	P	Mid Axle Centre to Rear Axle Centre	1 600 mm (5 ft. 2 in.)
B3	Bin Height - Fully Tipped	5 743 mm (18 ft. 10 in.)	Q	Mid Axle Centre to Front Axle Centre	3 865 mm (12 ft. 8 in.)
C	Width over Mudguards	2 568 mm (8 ft. 5 in.)	R	Front Axle Centre to Machine Front	2 357 mm (7 ft. 8 in.)
D	Width over Tyres - 20.5R25	2 550 mm (8 ft. 4 in.)	S	Front Axle Centre to Artic Centre	1 361 mm (4 ft. 5 in.)
E	Tyre Track Width - 20.5R25	2 022 mm (6 ft. 7 in.)	T	Approach Angle	26°
F	Width over Bin	2 540 mm (8 ft. 4 in.)	U	Maximum Bin Tip Angle	70°
F1	Width over Tail Lights	2 582 mm (8 ft. 5 in.)	V	Maximum Articulation Angle	45°
G	Width over Mirrors - Operating Position	3 260 mm (10 ft. 8 in.)	W	Front Tie Down Height	1 028 mm (3 ft. 4 in.)
H	Ground Clearance - Artic	479 mm (1 ft. 6 in.)	X	Machine Lifting Centres	8 845 mm (29 ft.)
I	Ground Clearance - Front Axle	444 mm (1 ft. 5 in.)	Y	Inner Turning Circle Radius - 23.5R25	3 954 mm (12 ft. 11 in.)
J	Ground Clearance - Bin Fully Tipped	704 mm (2 ft. 3 in.)	Z	Outer Turning Circle Radius - 23.5R25	7 309 mm (23 ft. 11 in.)
K	Ground Clearance - Under Run Bar	535 mm (1 ft. 9 in.)			

## Gradeability/Rimpull

1. Determine tractive resistance by finding intersection of vehicle mass line and grade line. NOTE: 2% typical rolling resistance is already assumed in chart and grade line.
2. From this intersection, move straight right across charts until line intersects rimpull curve.
3. Read down from this point to determine maximum speed attained at that tractive resistance.

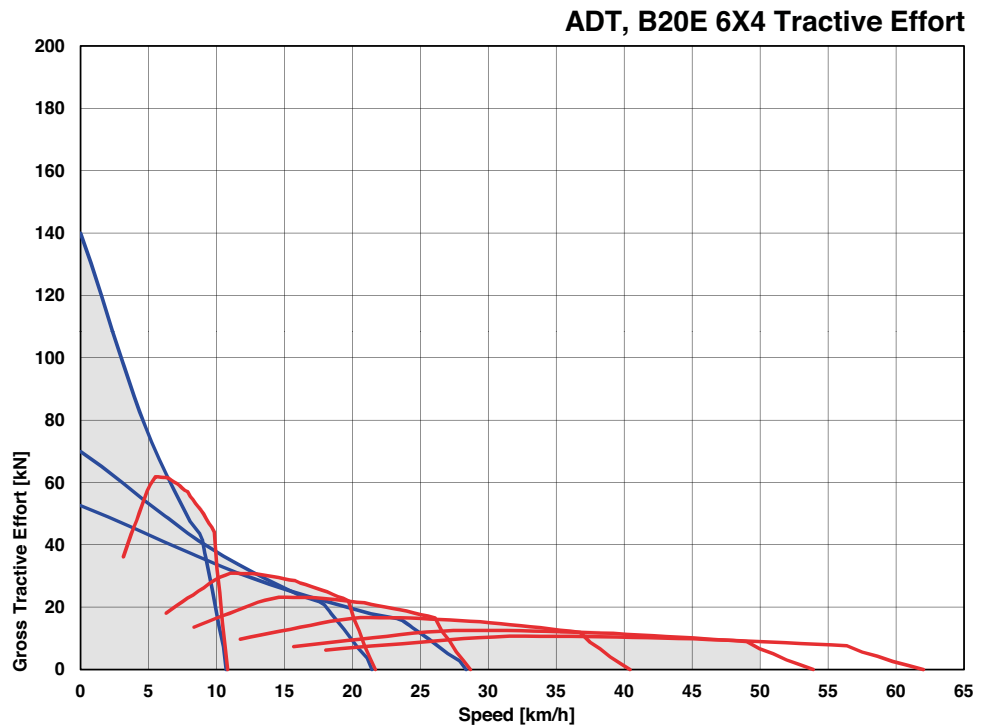
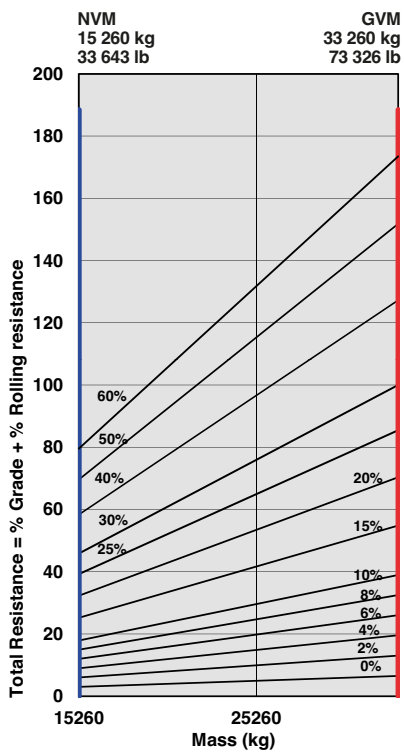

## Retardation

1. Determine retardation force required by finding intersection of vehicle mass line.
2. From this intersection, move straight right across charts until line intersects the curve. NOTE: 2% typical rolling resistance is already assumed in chart.
3. Read down from this point to determine maximum speed.

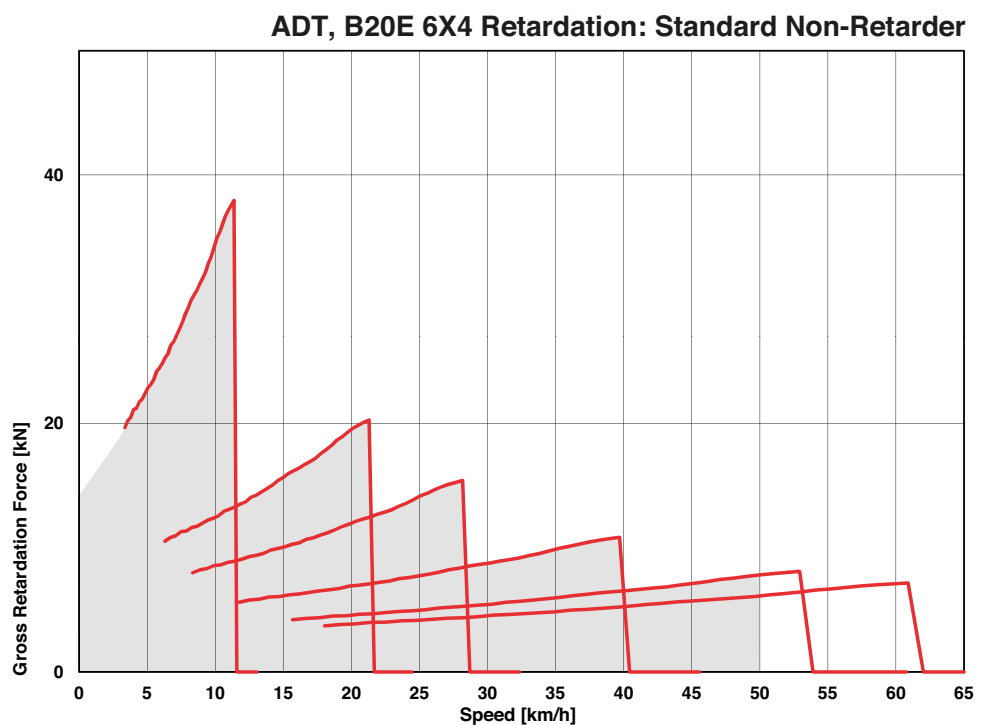
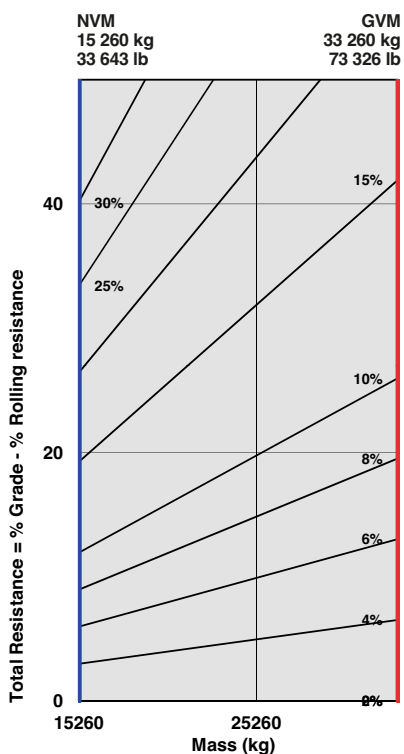

B18E	B20E	B25E (6x4)	B25E	B30E		B18E	B20E	B25E (6x4)	B25E	B30E	
<b>ENGINE</b>						<b>CAB (continued)</b>					
●	●	●	●	●	Engine valve brake and exhaust brake	●	●	●	●	●	Remote battery jump start
●	●	●	●	●	Dual element air cleaner with dust ejector valve	●	●	▲	▲	▲	High visibility mirrors
●	●	●	●	●	Precleaner with automatic dust scavenging	●	●	●	●	●	12-volt power outlet
●	●	●	●	●	Water separator	●	●	●	●	●	Cup holder
●	●	●	●	●	Serpentine drive belt with automatic tensioner	▲	▲	▲	▲	▲	Electric adjustable and heated mirrors
<b>COOLING</b>						●	●	●	●	●	Cooled/heated lunch box
●	●	●	●	●	Crankshaft mounted electronically controlled viscous fan drive	●	●	●	●	●	Backlit sealed switch module functions with: Wiper control / Lights / Heated mirrors / Retarding aggressiveness / Transfer case differential lock / Transmission gear hold / Dump-body tip limit / Automatic dump-body tip settings / Airconditioner/Heater controls / Preselected Speed Control
●	●	●	●	●	Fan guard	●	●	●	●	●	Deluxe 10" colour LCD: Speedometer / Fuel gauge / Transmission oil temperature gauge / Engine coolant temperature gauge / LED function/warning indicators and audible alarm / Transmission gear selection / Tachometer / Battery voltage / Hour meter / Odometer / Fuel consumption / Tip counter / Trip timer / Trip distance / Metric/English units / Service codes/diagnostics
<b>PNEUMATIC SYSTEM</b>						<b>DUMP BODY</b>					
●	●	●	●	●	Engine-mounted compressor	●	●	●	●	●	Partial up dump-body mechanical
●	●	●	●	●	Air drier with heater	▲	▲	▲	●	●	Fully up dump-body mechanical lock
●	●	●	●	●	Integral unloader valve	▲	▲	▲	▲	▲	Body liner
<b>ELECTRICAL SYSTEM</b>						▲	▲	▲	▲	▲	Tailgate
●	●	●	●	●	Battery disconnect	▲	▲	▲	▲	▲	Body heater
●	●	●	●	●	Drive lights	▲	▲	▲	▲	▲	Less dump body and cylinders
●	●	●	●	●	Air horn	▲	▲	▲	▲	▲	Greedy boards (200 mm)
●	●	●	●	●	Reverse alarm	<b>OTHER</b>					
▲	▲	▲	▲	▲	White noise reverse alarm	●	●	●	●	●	Automatic Traction Control (ATC)
●	●	●	●	●	Rotating beacon	●	●	●	●	●	20.5R25 Radial earthmover tyres
●	●	●	●	●	Pitch Roll sensor	●	●	●	●	●	23.5R25 Radial earthmover tyres
▲	▲	▲	▲	▲	LED Artic reverse light	●	●	●	●	●	Remote grease banks
▲	▲	▲	▲	▲	Halogen Artic reverse light	▲	▲	▲	▲	▲	Automatic greasing
●	●	●	●	●	LED reverse light	●	●	●	●	●	Onboard weighing
<b>STEERING SYSTEM</b>						▲	▲	▲	▲	▲	Load lights: stack
▲	▲	▲	▲	▲	Bi-directional ground driven secondary steering pump	▲	▲	▲	▲	▲	Comfort ride suspension (Front)
●	●	●	●	●	Ground-driven secondary steering pump	▲	▲	▲	▲	▲	Comfort ride suspension (Rear)
<b>CAB</b>						▲	▲	▲	▲	▲	Reverse camera
●	●	●	●	●	ROPS/FOPS certification	▲	▲	▲	▲	▲	HSE hand rails
●	●	●	●	●	Tilt cab	●	●	●	●	●	Cab peak
●	●	●	●	●	Gas strut-supported door	▲	▲	▲	▲	▲	High pressure hydraulic filter
●	●	●	●	●	I-Tip programmable dump-body tip settings	▲	▲	▲	▲	▲	Fuel heater
●	●	●	●	●	HVAC Climate control system	●	●	●	●	●	Belly cover
●	●	●	●	●	AM/FM radio with Aux + USB	▲	▲	▲	▲	▲	Cross member cover
●	●	●	●	●	Rear window guard	▲	▲	▲	▲	▲	Remote transmission filters
●	●	●	●	●	Wiper/washer with intermittent control	▲	▲	▲	▲	▲	Window smash button
▲	▲	▲	▲	▲	Extra wide wiper system	●	●	●	●	●	Electronic bonnet opening
●	●	●	●	●	Tilt and telescoping steering wheel	▲	▲	▲	▲	▲	
●	●	●	●	●	Centre-mount air-suspension seat						
●	●	●	●	●	Retractable 3-point seat belt						
●	●	●	●	●	Foldaway trainer seat with retractable seat belt						
▲	▲	▲	▲	▲	Rotating beacon: seat belt installation						
●	●	●	●	●	Halogen work lights						
▲	▲	▲	▲	▲	LED work lights						
▲	▲	▲	▲	▲	Remote engine and machine isolation						