

2304E

ARTICULATED TRACTOR

4x4



- Gross Power: 160 kW (214 hp)
- Gross Torque: 810 Nm (597 lbft)
- Gross Combination Mass: 56 000 kg

BELL

Technical Data - 2304E Articulated Tractor 4x4

<p>ENGINE</p> <p>Manufacturer Mercedes Benz</p> <p>Model OM924LA</p> <p>Configuration Inline 4, turbocharged and intercooled</p> <p>Gross Power 160 kW (214 hp) @ 2 200 rpm</p> <p>Net Power 152 kW (204 hp) @ 2 200 rpm</p> <p>Gross Torque 810 Nm (597 lbf) @ 1 200 -1 600 rpm</p> <p>Displacement 4,80 litres (293 cu.in)</p> <p>Auxiliary Brake Exhaust brake Engine Valve Brake (EVB)</p> <p>Fuel Tank Capacity 200 litres (53 US gal)</p> <p>Certification OM924LA meets Euro III emissions regulations</p>	<p>TRANSFER BOX</p> <p>Manufacturer Kessler</p> <p>Series W1400</p> <p>Layout Remote mounted</p> <p>Gear Layout Three in-line helical gears</p> <p>Output Differential Permanent interaxle differential lock</p> <p>AXLES</p> <p>Bell 18T Axle housings: fabricated steel Differentials: high input limited slip on front and rear axle. Final drive: outboard planetary. High torque, low speed suitable for dual wheels.</p> <p>BRAKING SYSTEM</p> <p>Service Brake Dual circuit, full hydraulic actuation Dry disc brakes with 6 calipers (4F, 2R). Maximum Brake Force: 132 kN (29 675 lbf) with standard tyres.</p> <p>Park & Emergency Spring applied air released, driveline mounted disc Maximum Brake Force: 242 kN (54 400 lbf)</p> <p>Auxiliary Brake Automatic exhaust valve brake and engine valve brake. Optional automatic, adjustable, integral, hydrodynamic transmission retarder. Output shaft speed dependant.</p> <p>Maximum Retardation 165 kW (221 hp) Standard continuous 540 kW (724 hp) with Maximum retarder option</p>	<p>WHEELS</p> <p>Standard Tyre: Size 23.5R25</p> <p>Standard Tyre: Type Cross-ply</p> <p>Optional Tyre 1: Size Dual 15X34</p> <p>Optional Tyre 1: Type Traction</p> <p>Optional Tyre 2: Size 620/75 R26</p> <p>Optional Tyre 1: Type Dual purpose (Traction and Haulage)</p> <p>FRONT SUSPENSION</p> <p>Semi-independent, leading A-frame supported by hydro-pneumatic suspension struts.</p> <p>HYDRAULIC SYSTEM</p> <p>Variable displacement load sensing</p> <p>Flow 165 l/min (44 gal/min)</p> <p>Pressure 28 MPa (4 061 psi)</p> <p>Filter 5 microns</p> <p>STEERING SYSTEM</p> <p>Double-acting cylinders with ground driven emergency steering pump.</p> <p>Lock to lock turns 4,32</p> <p>Steering Angle 45°</p> <p>PNEUMATIC SYSTEM</p> <p>Air drier with heater and integral unloader valve, serving park brake and auxiliary functions.</p> <p>System Pressure 810 kPa (117 psi)</p>	<p>ELECTRICAL SYSTEM</p> <p>Voltage 24 V</p> <p>Battery Type Two AGM (Absorption Glass Mat) type</p> <p>Battery Capacity 2 X 75 Ah</p> <p>Alternator Rating 28 V 80 A</p> <p>VEHICLE SPEEDS</p> <table border="1"> <tbody> <tr> <td>1st</td> <td>8 km/h</td> <td>5 mph</td> </tr> <tr> <td>2nd</td> <td>15 km/h</td> <td>9 mph</td> </tr> <tr> <td>3rd</td> <td>20 km/h</td> <td>12 mph</td> </tr> <tr> <td>4th</td> <td>28 km/h</td> <td>17 mph</td> </tr> <tr> <td>5th</td> <td>37 km/h</td> <td>23 mph</td> </tr> <tr> <td>6th</td> <td>43 km/h</td> <td>27 mph</td> </tr> <tr> <td>R</td> <td>6 km/h</td> <td>3 mph</td> </tr> </tbody> </table> <p>CAB</p> <p>ROPS/FOPS certified 74 dBA internal sound level measured according to ISO 6396.</p>	1st	8 km/h	5 mph	2nd	15 km/h	9 mph	3rd	20 km/h	12 mph	4th	28 km/h	17 mph	5th	37 km/h	23 mph	6th	43 km/h	27 mph	R	6 km/h	3 mph
1st	8 km/h	5 mph																						
2nd	15 km/h	9 mph																						
3rd	20 km/h	12 mph																						
4th	28 km/h	17 mph																						
5th	37 km/h	23 mph																						
6th	43 km/h	27 mph																						
R	6 km/h	3 mph																						
<p>TRANSMISSION</p> <p>Allison</p> <p>Model Standard Non Retarder: 3000P ORS</p> <p>Configuration Fully automatic planetary transmission with optional retarder.</p> <p>Layout Engine mounted</p> <p>Gear layout Constant meshing planetary gears, clutch operated</p> <p>Gears 6 Forward, 1 Reverse</p> <p>Clutch Type Hydraulically operated multi-disc</p> <p>Control Type Electronic</p> <p>Torque Control Hydrodynamic with lock-up in all gears</p>																								

Operating Weights

OPERATING WEIGHTS			
EMPTY	kg (lbs)	LADEN	kg (lbs)
Front	8 080 (17 820)	Front	10 600
Rear	4 740 (10 450)	Rear	10 600
Total	12 820 (28 270)	* Gross Vehicle Mass	21 200
		** Gross Combination Mass (braked trailer)	56 000
		** Gross Combination Mass (un-braked trailer)	22 000

* Gross Vehicle Mass (GVM) is the maximum allowable mass that the vehicle can accommodate with load transfer from trailers onto the vehicle. This is limited by permissible tyre loading. Quoted number is for Trelleborg 650/75R26 tyres.

** Gross Combination Mass (GCM) is maximum allowable mass for the vehicle plus laden trailers. The different values are for braked or unbraked trailers.

Dimensions

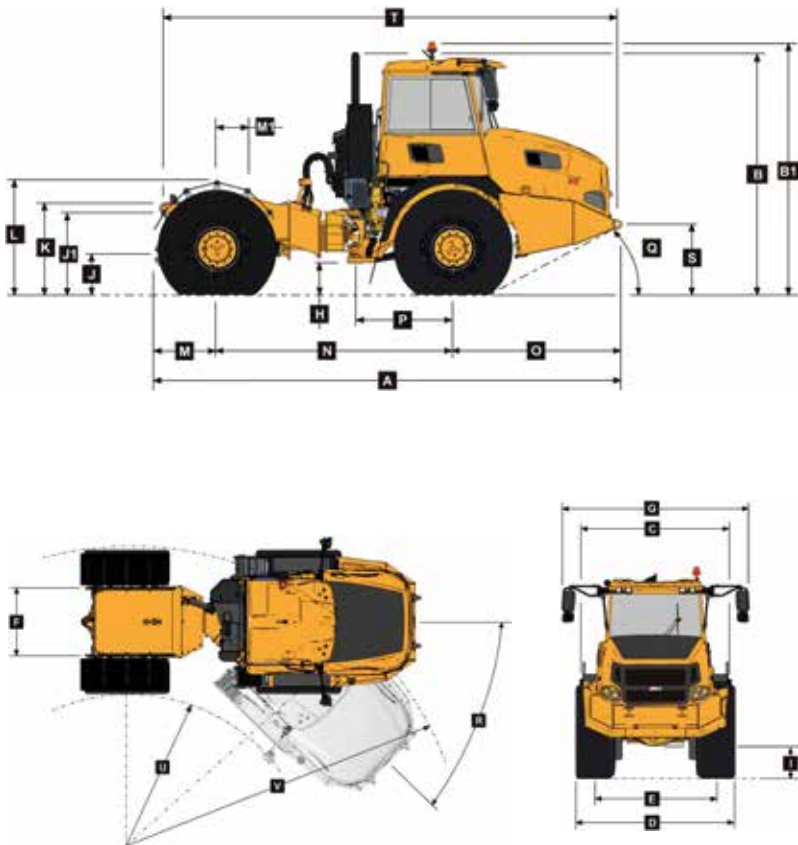

Machine Dimensions

A	Length-Transport Position	6 767 mm
B	Height-Transport Position	3 500 mm
B1	Height-Rotating Beacon	3 645 mm
C	Width over Mudguards	2 985 mm
D	Width over Tyres-23.5R25	2 957 mm
D1	Width over Tyres-Dual 15x34	3 772 mm
E	Tyre Track Width-23.5R25	2 342 mm
E1	Tyre Track Width-Dual 15x34	2 701 mm
F	Width over Rear Chassis	1 310 mm
G	Width over Mirrors-Operating Position	3 260 mm
H	Ground Clearance-Artic	538 mm
I	Ground Clearance-Front Axle	479 mm
J	Hitch Centre Height	693 mm
J1	Ball Hitch Top Height(Optional)	1 312 mm
K	Rear Chassis Height	1 416 mm
L	Rear Mudguard Height	1 735 mm
M	Rear Axle Centre to Machine Rear	867 mm
M1	Rear Axle Centre to Ball Hitch Centre (Option)	356 mm
N	Rear Axle Centre to Front Axle Centre	3 296 mm
O	Front Axle Centre to Machine Front	2 604 mm
P	Front Axle Centre to Artic Centre	1 362 mm
Q	Approach Angle	25°
R	Maximum Articulation Angle	45°
S	Front Tie Down Height	1 048 mm
T	Machine Lifting Centres	6 567 mm
U	Inner Turning Circle Radius-23.5R25	2 382 mm
U1	Inner Turning Circle Radius-Dual 15x34	1 974 mm
V	Outer Turning Circle Radius-23.5R25	5 576 mm
V1	Outer Turning Circle Radius-Dual 15x34	5 983 mm

Unladen Tyre Deflections:
 Front: 80.53 mm, Rear: 43.29 mm, Tyre Free Diam: 1 612 mm

Gradeability / Rimpull

1. Determine tractive resistance by finding intersection of vehicle mass line and grade line. NOTE: 2% typical rolling resistance is already assumed in chart and grade line.
2. From this intersection, move straight left across charts until line intersects rimpull curve.
3. Read down from this point to determine maximum speed attained at that tractive resistance.

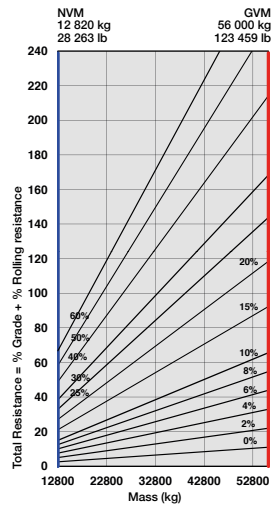

Articulated Tractor, 2304E 4x4 Tractive Effort

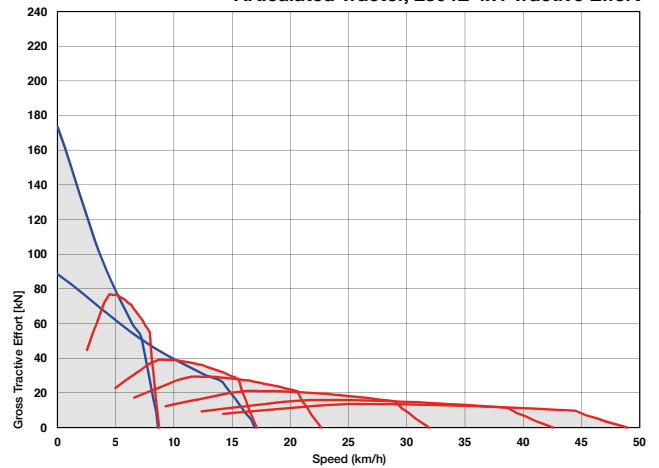

Retardation

1. Determine retardation force required by finding intersection of vehicle mass line.
2. From this intersection, move straight left across charts until line intersects the curve. NOTE: 2% typical rolling resistance is already assumed in chart.
3. Read down from this point to determine maximum speed.

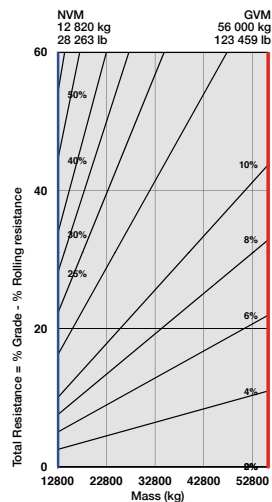

Articulated Tractor, 2304E 4x4 Retardation

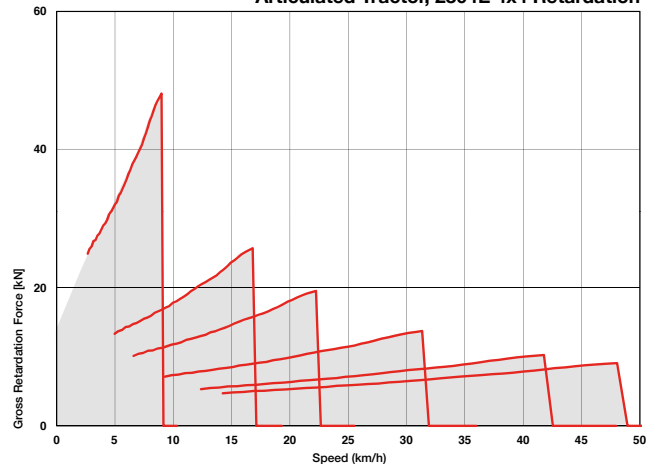

Features and Options

● STANDARD ▲ OPTION

ENGINE

- Engine valve brake and exhaust brake
- Dual element air cleaner with dust ejector valve
- Precleaner
- Water separator
- Serpentine drive belt with automatic tensioner

COOLING

- Crank-shaft mounted viscous-drive fan
- Fan guard

PNEUMATIC SYSTEM

- Engine-mounted compressor
- Air drier with heater
- Integral unloader valve

ELECTRICAL SYSTEM

- Battery disconnect
- Drive lights
- ▲ Deluxe work lights
- Electric hooter
- Reverse alarm
- Rotating beacon
- ▲ Artic reverse light

STEERING SYSTEM

- Ground-driven secondary steering pump

CAB

- ROPS/FOPS certification
- Tilt cab
- Gas strut-supported door
- Air conditioner
- Heater
- ▲ AM/FM radio/CD player
- Rear window guard
- Wiper/washer with intermittent control
- Tilt and telescoping steering wheel
- Centre-mount air-suspension seat
- ▲ LED work lights
- ▲ Rotating beacon: seat belt installation
- ▲ Remote engine and machine isolation
- ▲ Remote battery jump start

CAB (continued)

- Retractable seat belt
- Foldaway trainer seat with retractable seat belt
- ▲ High visibility mirrors
- 12-volt power outlet
- Cup holder
- Cooled/heated lunch box
- Ashtray
- ▲ Electric adjustable and heated mirrors
- Deluxe 10" colour LCD:
Speedometer / Fuel gauge /
Transmission oil temperature gauge /
Engine coolant temperature gauge /
LED function/warning indicators and audible
alarm / Transmission gear selection /
Tachometer / Battery voltage / Hour meter /
Odometer / Fuel consumption / Trip timer /
Trip distance / Metric/English units /
Service codes/diagnostics
- Backlit sealed switch module functions with:
Wiper control / Lights / Heated mirrors /
Retarding aggressiveness / Transfer case
differential lock / Transmission gear hold /
Airconditioner/ Heater controls /
Preselected Speed Control

OTHER

- 23.5R25 tyres
- ▲ 620/75R26 tyres
- ▲ Dual 15x34 Traction tyres
- Remote grease banks
- ▲ Automatic greasing
- Cab peak
- ▲ High pressure hydraulic filter
- ▲ Fuel heater
- ▲ Handrails
- ▲ Remote transmission filter

ATTACHMENT OPTIONS

- Goose neck (125 mm)
- ▲ Pin + Ballast
- Rear Hydraulics bulkhead blanking
- ▲ Rear Hydraulic bulkhead quick couplers

FEATURES OF ARTICULATED TRACTORS...

- **VALUE:** Bell tractors are not farm tractor derivatives.
They are built from the ground up for trouble free operation and maximum durability in full-time heavy duty construction work.
- **PRODUCTIVE:** Powerful built-for hauling ADT drivetrains are well matched for pulling and retarding heavy loads.
Nitrogen over oil strut suspension smooths the ride for operator and machine.
- **ECONOMY:** Modern fuel efficient engine, lockup torque converter and planetary transmission deliver more work per unit of fuel used
- **EASY TO OPERATE:** High quality cab is conducive to operator care.
Simple to use controls and electronic interfaces protect the machine from accidental misuse.

All dimensions are shown in millimetres, unless otherwise stated between brackets.
Under our policy of continuous improvement, we reserve the right to change technical data and design without prior notice. Photographs featured in this brochure may include optional equipment.

BELL INTERNATIONAL: Tel: +27 (0)35-907 9431

E-mail: marketing@bellequipment.com

Web: www.bellequipment.com



Tel: +61 (0)8-9355-2442

Tel: +49 (0)6631 / 91-13-0

Tel: +27 (0)11-928-9700

Tel: +44 (0)1283-712862



Tel: +33 (0)5-55-89-23-56

Tel: +7-495-287-80-02

Tel: (704) 655 2802

**Strong Reliable Machines
Strong Reliable Support**

BELL