

STATIC DIMENSIONS

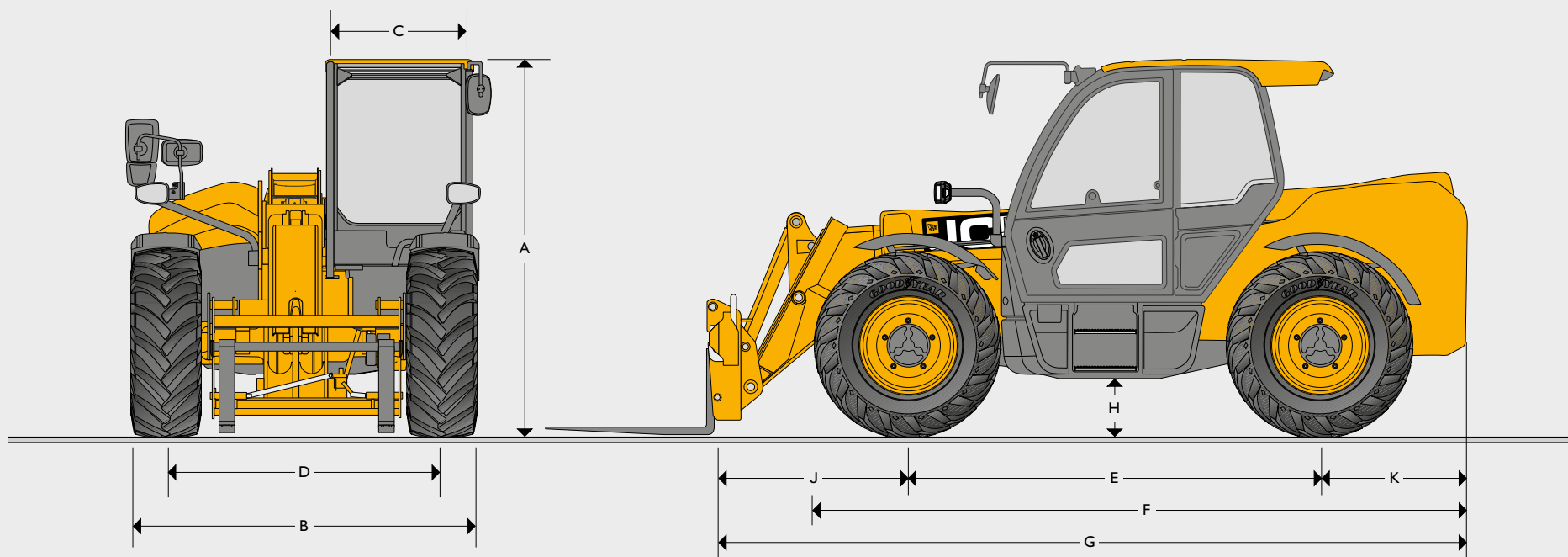

STATIC DIMENSIONS

Machine model		532-60	532-70	536-95	542-70	560-80
A	Overall height	m	2.49	2.49	2.49	2.67
B	Overall width (over tyres)*	m	2.28	2.34	2.34	2.49
C	Inside width of cab	m	0.97	0.97	0.97	0.97
D	Front track	m	1.81	1.81	1.87	1.99
E	Wheelbase	m	2750	2.75	2.75	2.75
F	Overall length to front tyres	m	2.75	4.38	4.38	4.38
G	Overall length to front carriage	m	4.69	4.99	4.99	4.99
H	Ground clearance	m	0.37	0.4	0.4	0.4
J	Front wheel centre to carriage	m	1.15	1.23	1.21	1.23
K	Rear wheel centre to rear face	m	0.65	1.01	1.03	1.01
	Turn radius - over tyres	m	3780	3.7	3.7	3.7
	Carriage rollback angle -for shovel in carry position	degrees	42.6	42.6	41	42.6
	Carriage dump angle - for shovel at full height	degrees	42.5	37.5	24	37.5
	Weight (AGRI, AGRI, AGRI Super)	kg	7520	7600	8760	8300
	Weight (AGRI Pro)	kg	NA	8370	8820	8520
	Tyres		400/80 R24	460/70 R24	460/70 R24	460/70 R24
						480/80 R26

Machine shown with roof mounted air conditioning fitted.

*Dependant upon tyre specified.

OPTIONS											
	532-60	532-70	532-70	532-70	536-95	536-95	542-70	542-70	542-70	560-80	560-80
	AGRI	AGRI	AGRITORQUELOCK4	AGRISUPER	AGRITORQUELOCK4	AGRISUPER	AGRITORQUELOCK4	AGRISUPER	AGRIPRO	AGRISUPER	AGRIPRO
Drivetrain											
109hp/81kW	X	X	X	-	X	-	X	-	-	-	-
125hp/93kW	-	-	-	X	-	X	-	○	-	-	-
145hp/108kW	-	-	-	○	-	○	-	X	X	X	X
Auto Reversing Fan	X	X	X	X	X	X	X	X	X	X	X
40kph Powershift (4-speed)	X	-	-	-	-	-	-	-	-	-	-
40kph Powershift (4-speed TorqueLock in 4th gear)	-	X	X	-	X	-	X	-	-	-	-
40kph Autoshift (6-speed TorqueLock in 5th & 6th gear)	-	-	-	X	-	X	-	X	-	X	-
40kph DualTech Variable Transmission, (combined Hydrostatic and Mechanical Drive with Flexi Mode)	-	-	-	-	-	-	-	-	X	-	X
Electrical 2/4WD disconnect	X	X	X	X	X	X	X	X	-	X	-
Auto 2/4WD disconnect	-	-	-	-	-	-	-	-	X	-	X
Limited slip differential in front axle	○	○	○	○	○	○	○	○	X	○	X
Smart Hydraulics											
Auto - Smooth Ride System	○	○	X	X	X	X	X	X	X	X	X
Electro hydraulic pin-locking	○	○	X	X	X	X	X	X	X	X	X
High flow double acting - auxiliary	○	○	○	○	○	○	○	○	X	○	X
Double acting - single rear auxiliary	○	○	○	○	○	○	○	○	○	○	○
Double acting - twin front auxiliary	○	○	○	○	○	○	○	○	○	○	○
Double acting - twin rear auxiliary	○	○	○	○	○	○	○	○	○	○	○
Sway: Electro-Hydraulically controlled chassis levelling	-	○	○	○	○	○	○	○	-	-	-
Cab											
Air suspension seat, with seat-mounted control pod	X	X	X	X	X	X	X	X	-	X	-
Heated air suspension seat with seat-mounted control pod	○	○	○	○	○	○	○	○	-	○	-
Half leather, heated and vented air suspension seat with seat-mounted control pod	-	-	-	○	-	○	-	○	X	○	X
Left hand armrest	X	X	X	X	X	X	X	X	X	X	X
Auto temperature climate control, air conditioning	○	○	○	○	○	○	○	○	○	○	○
Heated screen – rear	○	○	○	○	○	○	○	○	○	○	○
Heated screen – front	○	○	○	○	○	○	○	○	○	○	○
External screen guard – front	X	X	X	X	X	X	X	X	X	X	X
Lighting											
Halogen worklights – 2x front cab, 2 rear cab, 2x boom, 1x hitch light & interior light	X	X	X	-	X	-	X	-	-	-	-
LED worklights – 2x front cab, 2 rear cab, 2x boom, 1x hitch light & interior light	○	○	○	X	○	X	○	X	-	X	-
360° LED worklight package – 2x front cab & 2x rear chassis	○	○	○	○	○	○	○	○	X	○	X
LED road light package – front and rear road lights number plate light	○	○	○	○	○	○	○	○	○	○	○
Braking											
Twin line hydraulic trailer brakes* with 7 pin electrics & E.B.S socket	○	○	○	○	○	○	○	○	○	○	○
Twin line air trailer brakes* with 7 pin electrics & A.B.S socket	○	○	○	○	○	○	○	○	○	○	○
Twin line air trailer brakes* & single line hydraulic with 7 pin electrics & A.B.S socket	○	○	○	○	○	○	○	○	○	○	○
Other											
32T Hydraulic pick up tow hitch (must also take twin line trailer brakes)	○	○	○	○	○	○	○	○	○	○	○
Ladder mounted tow hitch (must also take twin line trailer brakes)	○	○	○	○	○	○	○	○	○	○	○
Boom ingress protection kit (7m & 8m only)	-	○	○	○	-	-	○	○	X	○	X
Remote centralised rear grease points (7m & 8m only)	-	○	○	○	-	-	○	○	X	○	X
Transmission belly guard kit	○	○	○	○	○	○	○	○	X	○	X

Standard X Optional ○ Not applicable -

*Complies as a European type approved vehicle as a T1a tractor. (Some options are territory dependant).

LIFT PERFORMANCE

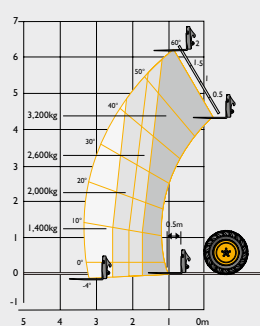
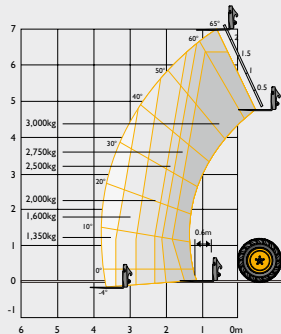
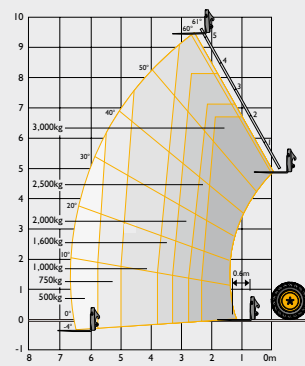
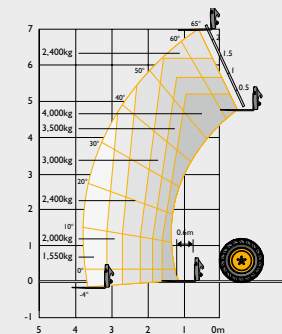
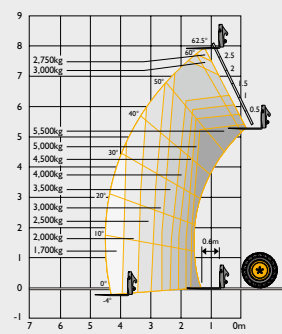
Machine model		532-60	532-70	536-95	542-70	560-80
						
Lift capacity - maximum	kg	3000	3000	3000	4000	5500
Lift capacity to full height	kg	3000	2750	1600	2400	2750
Lift capacity at full reach	kg	1400	1350	500	1550	1700
Lift height	m	6.22	7	9.49	7.01	7.9
Forward reach at maximum lift height	m	0.87	0.48	2.43	0.48	0.92
Maximum forward reach	m	3.43	3.82	6.60	3.82	4.51
Reach with 1 tonne load	m	3.43	3.82	5.00	3.82	4.51
Placing height	m	5.42	6.3	8.78	6.3	6.64

Complies with stability test: ISO 22915-14:2010.

ENGINE				
Manufacturer	JCB			
Model	EcoMAX			
Emissions level	UN Stage 3			
Aspiration	Turbocharged cooled			
Power rating				
Power @ 2200rpm	hp (kW)	109 (81)	125 (93)	145 (108)
Torque rating				
Torque @ 1500rpm	Nm	516	550	560
Specification				
Displacement	ltr	4.4	4.4	4.8
No. of cylinders		4	4	4
Bore size	mm	103	103	106
Stroke	mm	132	132	135

HYDRAULICS						
Model		532-60	532-70	536-95	542-70	560-80
Operating system pressure	bar	241	241	241	260	260
Main hydraulics	l/min	140	140	140	140	140
Pump type		Variable Displacement				
Hydraulic cycle times						
Lift	seconds	4.0	4.5	5.6	5	7.4
Lower	seconds	3.8	5.7	6.3	5.2	8.3
Extend	seconds	5.8	6.7	9.4	6.7	8.3
Retract	seconds	4.4	5	10	5	5.9
Bucket dump	seconds	2.3	2.9	1.9	5	2.8
Bucket crowd	seconds	1.8	2.3	2.5	2.3	3.0

SERVICE CAPACITIES			
Fuel tank	litres		169
Screenwash tank	litres		6.2
Hydraulic tank	litres		113
Coolant	litres		23
Engine oil sump	litres		14

ELECTRICAL SYSTEM			
System voltage	Volt		12
Alternator	Amp/hour		150
Battery capacity	Amp/hour		180

NOISE AND VIBRATION				
		Level	Uncertainty	Measurement conditions
A-weighted emission sound pressure level at Operator's position (LpAZ)	dB(A)	69	+/- 1	Determined in accordance with the test method and calculations defined in EN 12053:2001
Exterior sound (Stationary)	dB(A)	73	+/- 1	Determined in accordance with the test method defined in 2015/96 (Annex III)
Exterior sound (Moving)	dB(A)	84	+/- 1	
Whole body vibration	m/s2	1.03	50%	Determined in accordance with the test method defined in EN 13059 (Machine operating duty: Loader work (stone))
Hand-arm vibration	m/s2	<2.5	N/A	Determined in accordance with the test method defined in ISO 5349-2: 2001

STANDARD MACHINE FEATURES		
Transmission	AGRI	<p>JCB Powershift transmission incorporating torque converter, bevel box and a 4 speed Powershift gearbox in one resiliently mounted unit.</p> <p>Operating modes: Manual gear shift incorporated onto the single lever joystick with 4 forward and 4 reverse Powershift gears.</p> <p>Travel speed: 40kph.</p> <p>Electrical 2/4 wheel drive disconnect.</p> <p>Switchable transmission disconnect on brake pedal.</p>
	AGRI TorqueLock 4	<p>JCB Powershift transmission incorporating torque converter, bevel box and a 4 speed Powershift gearbox with TorqueLock in 4th gear in one resiliently mounted unit.</p> <p>Operating modes: Manual gear shift incorporated onto the single lever joystick with 4 forward and 4 reverse Powershift gears.</p> <p>Travel speed 40kph.</p> <p>Electrical 2/4 wheel drive disconnect.</p> <p>Switchable transmission disconnect on brake pedal.</p>
	AGRI Super	<p>JCB Autoshift transmission incorporating torque converter, bevel box and 6-speed powershift gearbox with TorqueLock in 5th and 6th gear in one resiliently mounted unit.</p> <p>Operating modes: Manual and Auto gear shifts incorporated onto the single lever joystick with 6 forward and 4 reverse Powershift gears.</p> <p>Travel speed 40kph.</p> <p>Electrical 2/4 wheel drive disconnect.</p> <p>Auto selection between 4th and 6th gear in Auto mode.</p> <p>Switchable transmission disconnect on brake pedal.</p>

STANDARD MACHINE FEATURES (CONTINUED)		
Axles	AGRI Pro	<p>JCB DualTech Variable Transmission incorporating bevel box, combining hydrostatic and 3 speed direct drive mechanical Powershift gearbox with Flexi mode in one resiliently mounted unit.</p> <p>Operating modes: Flexi mode, Manual and Auto Drive (D), gear shift incorporated onto the single lever joystick with 1 forward and 1 reverse hydrostatic and 3 forward Powershift gears.</p> <p>Travel speed 40kph.</p> <p>Auto 2/4 wheel drive disconnect</p> <p>Auto selection when in Drive (D) mode.</p> <p>Permanent inching function on the brakes pedal.</p>
	AGRI / AGRI Super	<p>Front and rear drive: JCB epicyclic hub reduction drive/steer axles with Max-Trac torque proportioning differentials. (LSD option).</p> <p>When 2WD front axle drive.</p>
Brakes	AGRI Pro	<p>Front and rear drive: JCB epicyclic hub reduction drive/steer axles with Front: Limited Slip Differential (LSD) (Maxtrac option) and Rear: Max-Trac torque proportioning differential.</p> <p>When 2WD rear axle drive.</p>
		<p>Service brakes: Hydraulically activated, self-adjusting, oil-immersed in-board high back-off multi-disc type on front axle. Hydraulically powered service brakes on all model variants.</p> <p>Parking brake: SAHR (Spring Applied Hydraulic Release) park brake.</p> <p>Trailer brakes: Twin line pneumatic trailer brakes and Antilock Braking System (ABS).</p>
Steering		Hydrostatic power steering with power track rods on both axles, 3x steering modes: two wheel steer, four wheel steer, crab steer.

STANDARD MACHINE FEATURES (CONTINUED)	
Hydraulic controls	Single lever servo joystick, incorporating forward/neutral/reverse, with progressive extend/retract and auxiliary incorporating adjustable constant flow facility.
Boom and carriage	<p>Boom is manufactured from high tensile steel.</p> <p>JCB Q-fit self-levelling carriage with lever operated pin locking accepts pallet forks and a wide range of attachments.</p>
Deluxe cab	<p>Quiet, safe and comfortable cab conforms to ROPS ISO 3471 and FOPS ISO 3449.</p> <p>Tinted glass all round with laminated front and roof screen. Roof bars, front, rear and roof screen wash/wipe and heater/screen demister.</p> <p>Opening rear window. Single integrated front and roof screen blind.</p> <p>Audio-visual warning system for coolant temperature, water in fuel, engine oil pressure, air cleaner, battery charge, transmission oil temperature and pressure.</p> <p>Hourmeter and road speed indicator.</p> <p>Engine temperature, fuel gauge and clock.</p> <p>Adjustable steer column with stalk bar forward reverse shuttle.</p> <p>Bluetooth radio with integrated hands free microphone.</p> <p>Automatic eye level audio-visual load moment indicator warning system receiving a signal from a load sensor on the rear axle. This system continuously monitors the machine's forward stability and leaves the operator in control at all times.</p>
Options and accessories	<p>A range of tyres for Traction, flotation, Agri-Industrial etc.</p> <p>Beacons. Fire extinguisher. Electro – hydraulic pin locking. Wheel nut torque indicators. Automatic air conditioning – climate control. Heated front windscreen. Under protection.</p> <p>Various carriage options are available – contact your local dealer.</p>
Sway	Hydraulically controlled front axle leveling system on Plus and Super models only (542-70 & 536-95 models only)