

**STATIC DIMENSIONS**

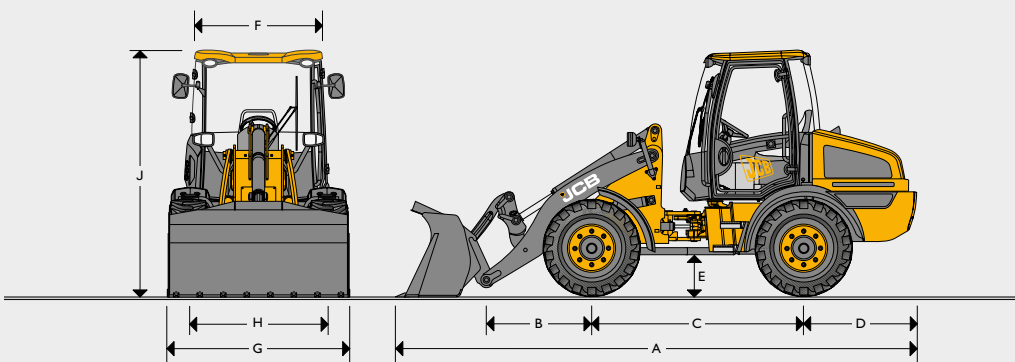

A	Overall Length	mm	5133
B	Axle to pivot pin	mm	906
C	Wheel Base	mm	2100
D	Axle to counterweight face	mm	1268
E	Ground clearance	mm	313
F	Width over cab	mm	1468
G	Width over tyres	mm	1727
H	Wheel track	mm	1390
J	Height Over Cab	mm	2500
	Front axle weight	kg	1475
	Rear axle weight	kg	3398
	Total weight	kg	4873
	Inside Turn Radius	mm	2010
	Maximum Turn Radius over Shovel	mm	4160
	Articulation Angle	deg	±40°
	Maximum radius over tyre	mm	3800
	Max. width across tyres	mm	1761

Data based on machine equipped with pin mounted 0.8m<sup>3</sup> bucket with toe plates and Camso SLR4 12.5-18 tyres.

**ENGINE**

Type	4 stroke, Mechanical	
Model	JCB Diesel by Kohler - KDI 2504 M	
Capacity	litres	2.482
Aspiration	Normally aspirated	
Cylinders	4	
Max gross power to SAE J1995/ISO 14396	kW (hp)	36.4 (49) @ 2600rpm
Max torque	Nm @ 1500rpm	170
Emissions	Stage IIIA	

**TRANSMISSION**

Type	Hydrostatic		
Model	Rexroth A6VM1 – 2 speed		
Low range	kph	6	
High range	kph	20	

**LOADER DIMENSIONS**

Model (assumes machine is fitted with Camso SLR4 12.5-18 tyres)	General purpose	General purpose	Light duty	Light duty	6-in-1 clam shovel
Bucket type	Teeth or toeplate	Teeth or toeplate	Teeth or toeplate	Teeth or toeplate	Teeth or toeplate
Bucket equipment	Teeth or toeplate		Toeplate		Teeth or toeplate
Bucket capacity (SAE heaped)	m <sup>3</sup>	0.8	1	1.2	1.4
Bucket width	mm	1900	1900	1900	1900
Bucket weight	kg	287	322	353	384
Maximum material density	kg/m <sup>3</sup>	2050	1620	1320	1120
Tipping load straight	kg	4225	4148	4055	4014
Tipping load full turn	kg	3250	3191	3120	3088
Payload	kg	1625	1595	1560	1544
Maximum breakout force	kN	41.9	36.5	32.2	29.7
M Dump angle maximum	degrees	45	45	45	45
N Roll back angle full height	degrees	56	56	56	56
O Roll back at carry	degrees	54	54	54	54
P Roll back at ground level	degrees	42	42	42	42
Q Load over height	mm	2991	2991	2991	2991
R Dump height (45 deg dump)	mm	2489	2418	2348	2295
S Dig depth	mm	105	105	105	105
T Reach at dump height	mm	764	835	905	958.5
Reach maximum (45deg dump) – horizontal arm	mm	1494	1465	1635	1689
Operating weight (includes 80Kg operator and full fuel tank)	kg	4873	4907	4938	4969
V Pin height	mm	3120	3120	3120	3120

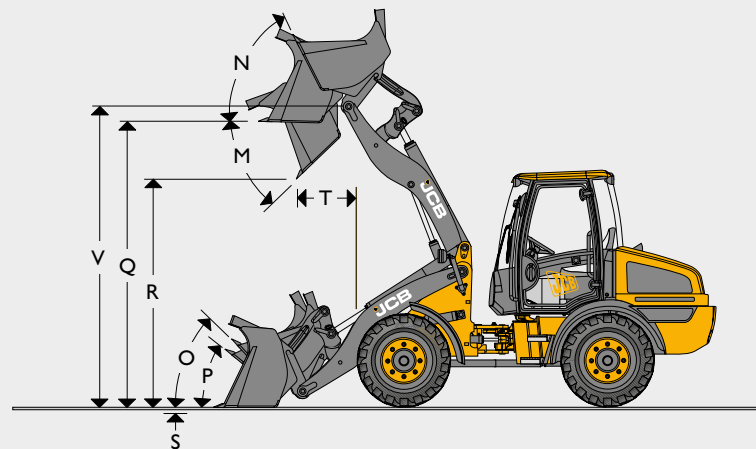

TYRE SIZE					
Tyre size	Manufacturer	Type	Operating weight (kg)	Dimensions	
				Vertical (mm)	Width (mm)
335/80 R18	Dunlop	SPT9 EM	41.2	-4	0
365/70 R18	Dunlop	SPT9 EM	64	-14	69
405/70 R18	Dunlop	SPT9 EM	94	9	113
335/80 R20	Dunlop	SPT9 MPT	77.6	22	-22
340/80 R18	Michelin	XMCL	71.6	28	25
340/80 R18	Michelin	BIBLOAD	65.6	-15	13
12.5-18	Mitas	MPT-04	31.6	9	-6
340/80 R18	Nokian	TRI 2	55.6	6	12
12.5/80-18	Camso	SLR4	0	1	-15
400/70 R18	Trelleborg	TH400	111.6	-15	137

Loader dimensions quoted on Camso SLR4 12.5-18 tyres.

#### LOADER DIMENSIONS – FORK FRAME WITH FORKS

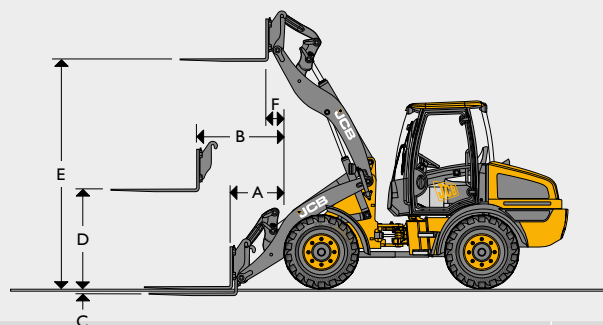

		Parallel fork
Fork carriage width	mm	1345
Length of tines	mm	1200
A Reach at ground level	mm	710
B Reach at arms horizontal	mm	1232
C Below ground level	mm	84
D Arms, horizontal height	mm	1426
E Arms, maximum height	mm	3012
F Reach at maximum height	mm	506
Payload*	kg	2033
Tipping load straight	kg	3184
Tipping load full turn (40°)	kg	2541
Attachment weight	kg	191

\*At the centre of gravity distance 500mm. Based on 80% of FTTL as defined in ISO 8313. Manual fork spacings at 50mm increments. Fork section 100mm x 50mm.

AXLES	
Type	Straight beam
Make and model	Dana 111
Chassis angle oscillation	degrees ± 10

STEERING	
	Hydraulic power steering system emergency steering.

ELECTRICAL SYSTEM		
System voltage	Volt	12
Alternator output	Amp hour	80
Battery capacity	Amp hour	100

HYDRAULICS		
Pump type		Tandem Gear Pump
Pump max. flow	l/min	64
Pump max. pressure	bar	230
Auxiliary flow	l/min	60
Hydraulic cycle times at max. engine		
Arms raise (full bucket)	Seconds	4.9
Bucket dump (full bucket)	Seconds	3.5
Arms lower (empty bucket)	Seconds	3.1
Total cycle	Seconds	11.5

SERVICE FILL CAPACITIES		
Hydraulic system	litres	70
Fuel tank	litres	80
Engine oil sump	litres	11.2
Axle oil (front)	litres	4.4
Axle oil (rear)	litres	6.05

STANDARD EQUIPMENT	
<b>GENERAL MACHINE FEATURES</b>	Parallel lift geometry, JCB Hydraulic Quickhitch, articulated steering, front and rear fenders, one piece opening bonnet, recovery hitch, lifting lugs.
<b>TRANSMISSION</b>	Two speed, neutral start, inching function, forward/reverse switch on joystick control lever.
<b>BRAKES</b>	In board oil immersed brakes with combined handbrake; cable operated parkbrake.
<b>ELECTRIC</b>	Full Road Lighting, Direction Indicators and Battery Isolator.
<b>HYDRAULICS</b>	Single lever manual control, gear pump with priority steer, emergency steer back up.
<b>CAB</b>	ROPS/FOPS safety structure, fully adjustable seat, interior light, adjustable tilt steering column, safety glass, front and rear screen wash/wipe, 3 speed heater fan with replaceable filters, sun visor.

OPTIONAL EQUIPMENT	
HBCV, 4th Spool aux circuit manual, LSD axles, fully opening RH window with lock back, immobiliser, livelink, under bonnet battery isolator, worklights, bio oil, shovel level indicator, stowage box. See dealer for full list.	

NOISE AND VIBRATION				
			Uncertainty	Measurement conditions.
Noise at the operator station	LpA	77 dB	+/- 1 dB	Determined in accordance with the test method defined in ISO 6396 and the dynamic test condition defined on 2000/14/EC.
Noise emission from the machine	LWA	101 dB	+/- 1 dB	Guaranteed equivalent sound power (external noise) determined in accordance with the dynamic test conditions defined in 2000/14/EC.
Whole body vibration	m/s <sup>2</sup>	0.59	+/- 0.11 dB	ISO 2632-1:1997 normalised to an 8h reference period and based upon a test cycle comprising of loader work (soil).
Hand-arm vibration	m/s <sup>2</sup>	<2.5	N/A	ISO 5349-2:2001 dynamic test conditions.