

Water Tankers

2806E
16 000 L

B18E
18 000 L

B25E
23 000 L

B30E
27 000 L

B40E
35 000 L

B45E
38 000 L

B50E
45 000 L

B60E
50 000 L

PIN 3: Stage II & Stage IIIA Certified



BELL

The full package

A single point solution for all your needs. Bell Equipment's Water Tankers provide a completely integrated solution that delivers the greatest performance while providing reliable support.

As a global leader in Articulated Water Trucks, Bell Equipment brings you a complete OEM solution packed with class leading features that deliver production boosting performance, lower daily operating costs, superior ride quality and uncompromised safety standards.

- Ergonomic in-cab controls provide fatigue-beating operation, efficient water use, and rapid operation.
- Advanced performance information is readily available to the operator to enhance performance and turnaround times.
- The full integration of all systems has enabled the development of innovative control features that expand the machine's functionality.
- Daily operational costs are reduced thanks to advanced fuel saving technology coupled with high strength lightweight material.



With a strong legacy in mining and construction, the Bell Water Tanker is designed to withstand all heavy duty applications.

A wide range of options and intelligent operation deliver best performance in dust suppression to increase visibility on site and provide effective pulmonary disease prevention.

Innovative control features provide the accuracy required in material hydration applications and flexibility for firefighting requirements.

Bell E-series Water Tankers will give your business the competitive edge you need.

Intelligence at your fingertips...

In-cab controls provide an ergonomic solution to control all implements and reduce operator fatigue and water wastage.

Leveraging the advanced system control and diagnostics capabilities has enabled the development of innovative features including:

- Auto spread: Ensures a uniform spread of water regardless of vehicle speed
- Ramp spray: Hill adjusted flow rate
- On board weighing: The volume of water in the tank is displayed on the display unit
- Pulse mode: Creates variable bursts of water to preserve water
- Reverse camera display: Viewable on the display unit during operation to see the spray of water from the cab

The pump speed is automated to provide the required flow rates for all activated implements. The automation of the pump speed removes complexity for the operator, improving performance and comfort. Full control or minor adjustments to the pump speed is possible with the use of the sealed switch module.

The optional remote water cannon can be controlled with the joystick. Rotating the joystick varies the spray pattern while the height and direction of the cannon is adjusted by shifting the joystick.

Each implement can be controlled with a dedicated push button on the sealed switch module. This enables individual activation of each of the valves. The dribble bar is split in half to provide further control.



Our wide range of optional implements provide the customisation needed to meet any job requirement.

A remote or manual water cannon can be fitted to the top of the tank to provide the height to target a jet of water at a desired target. The spread pattern can be altered from a fog to stream pattern while the flow rate can be adjusted with the use of the pump speed.

Five spray valves are standard on the rear of the water tank. Three in a horizontal configuration and two in a vertical configuration (batter sprays).

Optional hoses are available ranging from retractable hose reels to lay flat hoses.

The choice of gravity fed or pressurised penetration spray bar is available for the rear of the water tank. The pressurised option has nozzles to enhance the penetration potential of the spray bar.

Custom implements can be controlled with the flexible control electronics for further customisation.



Our quiet operator cabins are ROPS/ FOPS certified with an air suspension operator seat. The trainer seat has a retractable lap belt while the operator seat has a standard 3-point seat belt. Both have automatically locking retractors.

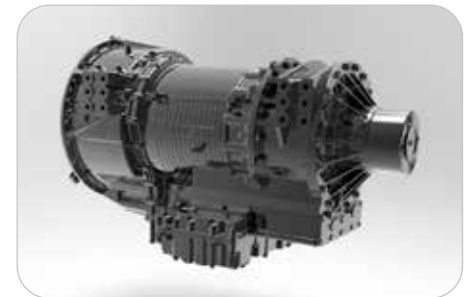

The planetary powershift transmission optimises shift points to match conditions and vehicle weight while protecting the transmission from operator error and abuse. Allison FuelSense® calibration optimises production and fuel burn.



The transfer case inter-axle differential delivers equal torque to each axle when traction is favourable. When conditions deteriorate, the diff-lock automatically engages to deliver torque to the tyres that can best use it.



High-strength steel and widely spaced taper roller bearings in the articulation area enhance long-term durability.



Our innovative front and rear comfort ride suspension options are offered to even further enhance ride quality and ensure minimal whole body vibration exposure.



- The water tank is designed to have a low centre of gravity for vehicle stability. Baffle plates further improve this stability by reducing sloshing effect of the water inside the water tank.

- Handrails are fitted along the staircase and on top of the water tank to ensure the safety of all roof access requirements. The plumbing is also routed internally to prevent any tripping hazards.

- Guards on the tank inlet to the pump and additional filters on the reservoir filling pipe protect the pump from any impurities. Safety reminders for the filling of the water tank from a reservoir are displayed.

- The park brake automatically applies when neutral is selected and it is not possible to engage neutral at speed. Torque dependent park brake release (Hill Assist) ensures no roll back on slopes.

- Best-in-class retarder and engine braking automatically applies when the operator lifts his foot off the accelerator. Retarder aggressiveness can be simply adjusted on the sealed switch module ensuring maximum descent control for all conditions.

- The short front end provides the best approach angle that allows these Water Tankers to attack steep terrain.

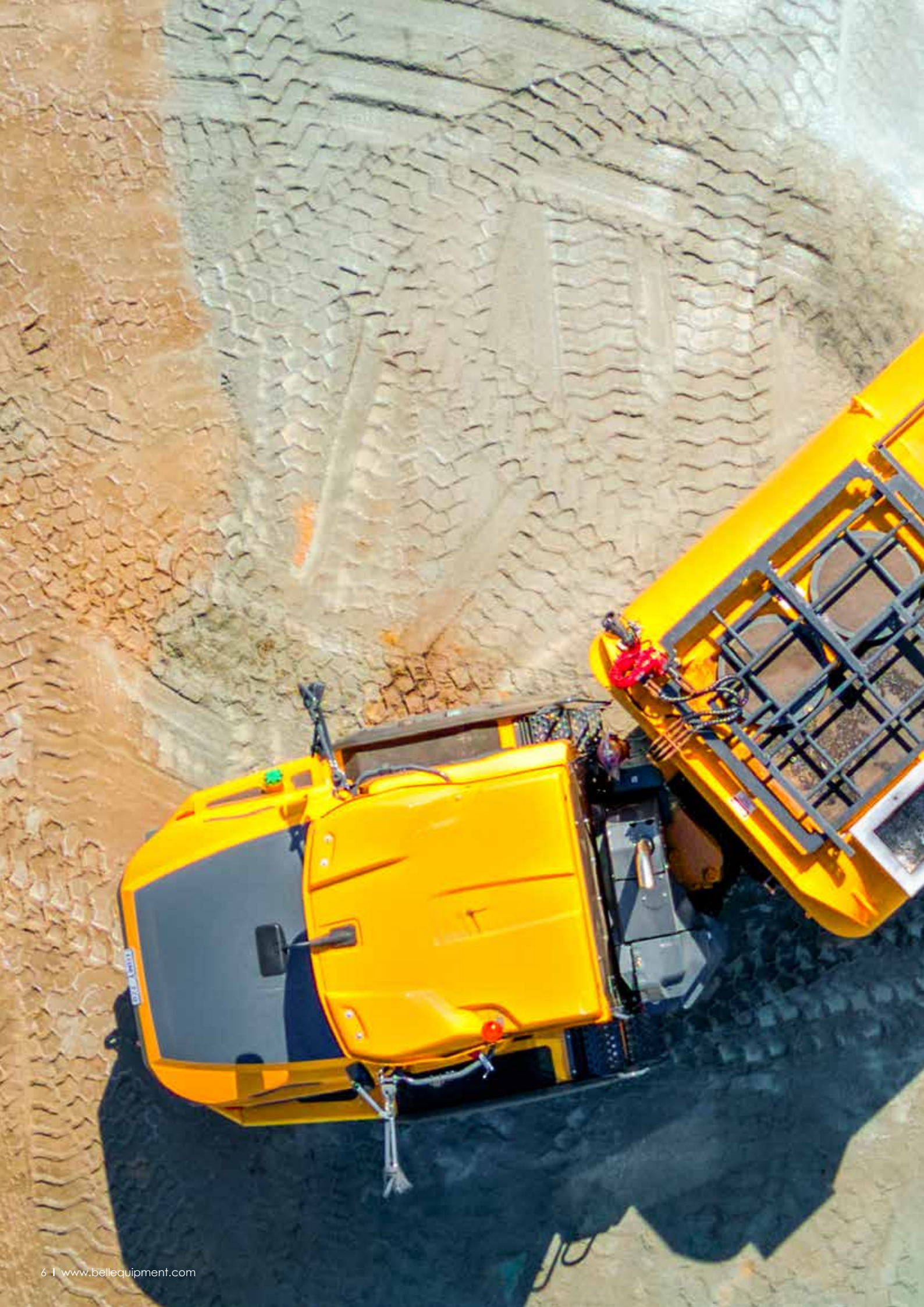



Reliable Performance

- With their oscillating frame and high-flotation tyres, Bell trucks won't leave you stuck. The articulation ensures manoeuvrability to get in and out of tight spots.
- Every water tank is pressurised during inspection to meet the highest quality standards.
- The use of high strength, lightweight materials coupled with fuel saving technology give these trucks the best fuel efficiency.
- The tank is constructed with internal baffle plates, which enhance the rigidity of the tank while providing greater stability. The tank is coated internally with an epoxy lining to prevent rust and prolong the life span of the product.
- Serviceability is enhanced with the pump and components being ground level accessible.
- Complete system integration enables the remote monitoring of live vehicle information for ease of fleet management.

Maximise your uptime

The E-series is loaded with features that make it as easy to maintain as it is to operate. Spend less time and expense getting ready for work and more time getting work done.

Easy-to-reach dipsticks and grouped service points make quick work of the daily routine. Quick-change filters together with extended engine and hydraulic oil-service intervals lower daily operating costs and provide superior machine uptime.

The industry leading, 10" colour monitor offers on-board machine diagnostics as well as automated daily service functionality, coupled with diagnostic test ports, for ease of troubleshooting and informing maintenance decisions on site.



If something goes wrong, the diagnostic monitor provides service codes and supporting info to help diagnose the problem.



The cab can be tilted in minutes without special tools, for convenient service access to drivetrain components.



An in-cab load centre simplifies fuse replacement. Fewer relays, connectors and harnesses mean higher reliability.



The remote transmission filter option makes transmission filter replacement an even faster and cleaner task.



- Automated daily service checks can be done with ease and comfort from inside the operator station using the 10" colour LCD monitor and sealed display controller.

- The load-sensing hydraulic system was designed with simplicity in mind, while maintaining efficiency. Fewer components for improved reliability and serviceability.

- Extended engine transmission and hydraulic oil-change for increased uptime and lower operating cost.

- Available environmental drains allow quick, no-spill changes.

- Your Bell Service Centre has the parts and backup you need to stay productive and offers a wide variety of preventative maintenance and support programmes to help you control costs.



See-through fluid reservoirs and sight gauges let you check fluid levels at a glance.



Easily accessible test ports allow technicians to troubleshoot problems more quickly.



Welcome to the ...

BELL Family

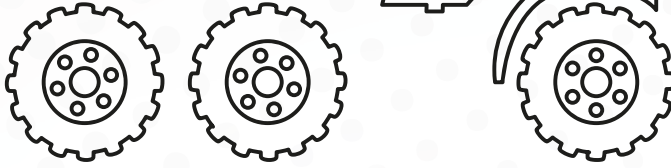

“Power up and plug in to our end-to-end customer solutions!”

START

Through our living motto **‘Strong Reliable Machines, Strong Reliable Support’**, we offer both exceptional equipment and aftermarket support products because we want your Bell ownership experience to be a happy one.



SETTING YOU UP FOR SUCCESS



TRAINING



PROTECTING YOUR ASSETS



LUBE CHECK



MAINTENANCE CONTRACT



EXTENDED WARRANTY



FLEETM@TIC®



KEEPING YOUR MACHINE RUNNING

LUBRICANTS

PARTS

SERVICE KITS

TECHNICAL SUPPORT

SPECIAL TOOLS

BELL OUTLETS

GIVING YOU EXTRA VALUE, LONGER LIFE



REMAN COMPONENTS



PRE-OWNED EQUIPMENT

SUPPORTING YOU EVERY STEP OF YOUR BELL OWNERSHIP EXPERIENCE

Smarter fleet management



Cutting edge technology, helping you run your fleet smarter. Providing accurate, up-to-date operational data, production data and diagnostic data.

The key to a productive and profitable fleet, lies in the ability to monitor and manage your machines and operators efficiently. Machine operational data is processed and compiled into useful production and performance statistics, accessible via the Bell Fleetm@tic® website. These reports are also automated and emailed directly to you. The two monitoring packages that we have available, are:

- **The Classic Package** supplies you with good enough information for you to have a very good understanding of how your machines is operating for each shift that it runs. This package comes standard with the machine for 2 years.
- **The Premium Package** is focused on customers who need to have extremely detailed information of the machine's operation. For this package we offer similar information to that of the Classic Package but for each individual laden - unladen cycle. In addition, live tracking is available on the Fleetm@tic® website on a per minute basis.

Fleetm@tic®:

- Maximise productivity
- Generate machine utilisation reports
- Identify operator training requirements
- Pro-active maintenance planning
- Implement safety features
- Receive machine fault codes as well as suggested trouble shooting procedures
- Protect investments
- Receive real time geospatial data



2806E 4x4 16 000 L Articulated Water Tanker

ENGINE

Manufacturer
Mercedes Benz

Model
OM906LA

Configuration
Inline 6, turbocharged and intercooled.

Gross Power
205 kW (275 hp) @ 2 200 rpm

Net Power
198 kW (265 hp) @ 2 200 rpm

Gross Torque
1 100 Nm (811 lbf) @
1 200 -1 600 rpm

Displacement
6,37 litres (389 cu.in)

Auxiliary Brake
Exhaust Valve Brake
Engine Valve Brake

Fuel Tank Capacity
379 litres (100 US gal)

Certification
OM906LA meets EU Stage II/EPA
Tier 2 emissions regulations.

TRANSMISSION

Manufacturer
Allison

Model
3200P ORS

Configuration
Fully automatic planetary
transmission with optional
retarder.

Layout
Engine mounted

Gear layout
Constant meshing planetary
gears, clutch operated.

Gears
6 Forward, 1 Reverse

Clutch Type
Hydraulically operated multi-
disc

Control Type
Electronic

Torque Control
Hydrodynamic with lock-up in
all gears.

TRANSFER BOX

Manufacturer
Kessler

Series
W1400

Layout
Remote mounted

Gear Layout
Three in-line helical gears

Output Differential
Permanent interaxle differential
lock

AXLES

High torque, low speed suitable
for dual wheels.

Manufacturer
Bell

Model
15T

Differential
High input limited slip differential
with spiral bevel gears.

Final Drive
Outboard heavy duty planetary
on all axles

BRAKING SYSTEM

Service Brake
Dual circuit, full hydraulic
actuation Wet disc brakes.

Maximum Brake Force:
132 kN (29 675 lbf) with standard
tyres.

Park & Emergency
Spring applied air released,
driveline mounted disc

Maximum Brake Force:
242 kN (54 400 lbf)

Auxiliary Brake
Automatic exhaust valve brake
and engine valve brake.

Optional automatic, adjustable,
integral, hydrodynamic
transmission retarder. Output
shaft speed dependant.

Maximum Retardation
165 kW (221 hp) Standard
continuous
539 kW (723 hp) with Maximum
retarder option

WHEELS

Standard Tyre: Size
23.5 X 25 SRG

Standard Tyre: Type
Radial Earthmover

FRONT SUSPENSION

Semi-independent, leading
A-frame supported by hydro-
pneumatic suspension struts.

HYDRAULIC SYSTEM

Full load sensing system serving
the prioritized steering, body
tipping and brake functions.
A ground-driven, load sensing
emergency steering pump is
integrated into the main system.

Pump Type
Variable displacement load
sensing
piston

Flow
165 l/min (44 gal/min)

Pressure
28 Mpa (4 061 psi)

Filter
5 microns

STEERING SYSTEM

Double-acting cylinders with
ground driven emergency
steering pump

Lock to lock turns
4,1

Steering Angle
45°

PNEUMATIC SYSTEM

Air drier with heater and integral
unloader valve, serving park
brake and auxiliary functions.

System Pressure
810 kPa (117 psi)

ELECTRICAL SYSTEM

Voltage
24 V

Battery Type
Two AGM (Absorption Glass
Mat) type

Battery Capacity
2 X 75 Ah

Alternator Rating
28 V 80 A

VEHICLE SPEEDS

1st	8 km/h	5 mph
2nd	15 km/h	9 mph
3rd	20 km/h	12 mph
4th	28 km/h	17 mph
5th	37 km/h	23 mph
6th	43 km/h	27 mph
R	6 km/h	3 mph

WATER TANK

Tank capacity
16 000 Litres

WATER TANKER PLUMBING

Centrifugal water pump

Rate of Flow
Standard:
1 800 L/min with 50 m head

Option:
5 400 L/min with 70 m head

CAB

ROPS/FOPS certified 74 dBA
internal sound level measured

Load Capacity & Ground Pressure

OPERATING WEIGHTS		GROUND PRESSURE		LOAD CAPACITY	
UNLADEN		LADEN (No sinkage)		Rated Payload	16 000 litres (4 200 gallons)
	kg (lb)		kPa (Psi)		
Total	21 020 (46 341)	Front	255 (36)		
		Rear	445 (64)		
LADEN					
	kg (lb)				
Front	12 824 (28 272)				
Rear	24 034 (52 986)				
Total	36 858 (81 258)				

Dimensions

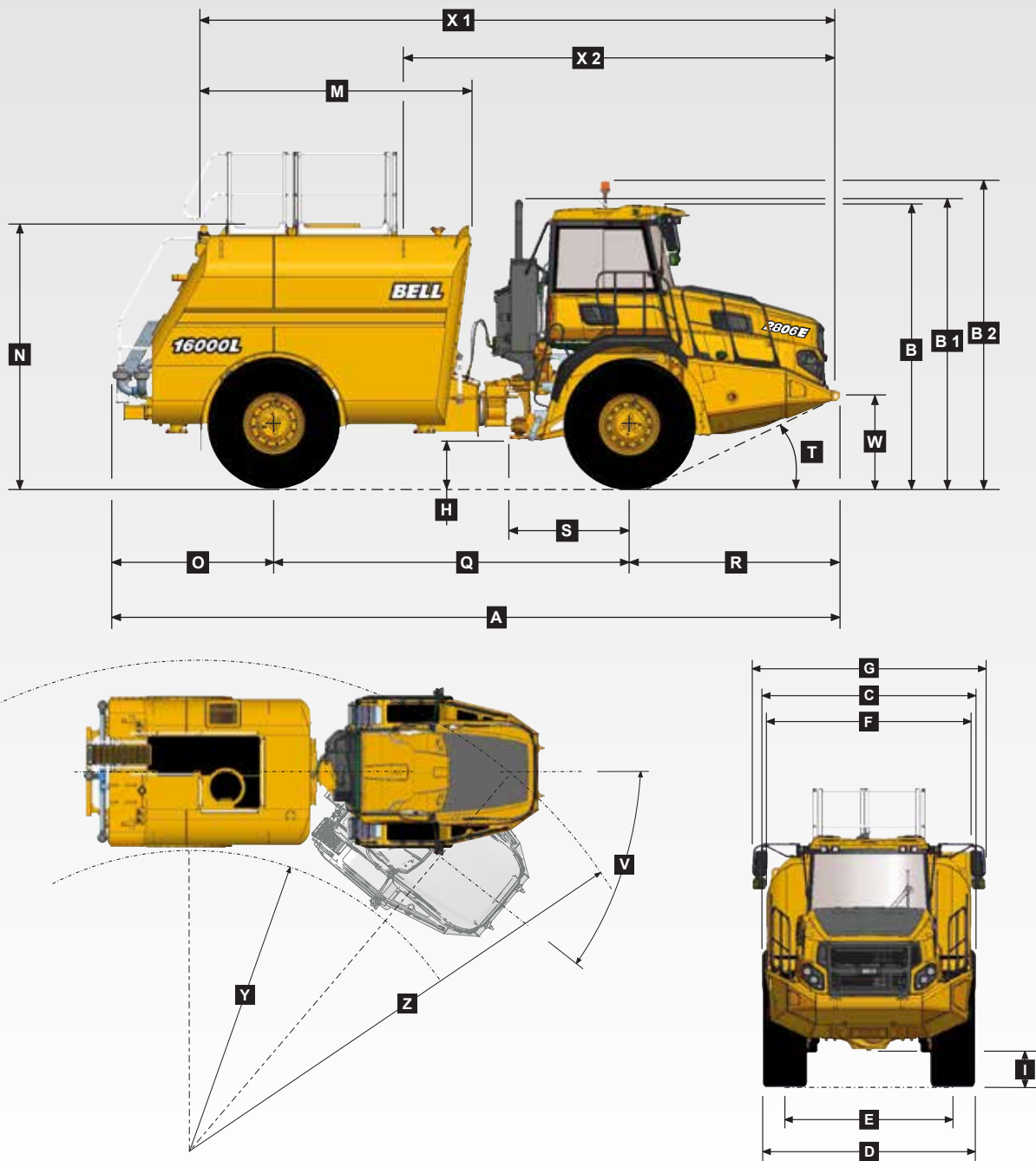

Machine Dimensions

A	Length - Transport Position	8 946 mm	(29 ft. 4 in.)	N	Maximum Tank Height	3 074 mm	(10 ft. 1 in.)
B	Height - Transport Position	3 436 mm	(11 ft. 3 in.)	O	Rear Axle Centre to Bowser / Tank Rear	1 950 mm	(6 ft. 5 in.)
B1	Height-Rotating Beacon	3 548 mm	(11 ft. 8 in.)	Q	Mid Axle Centre to Front Axle Centre	4 395 mm	(14 ft. 5 in.)
B2	Height-Exhaust	3 517 mm	(11 ft. 6 in.)	R	Front Axle Centre to Machine Front	2 601 mm	(8 ft. 6 in.)
C	Width over Mudguards	2 984 mm	(9 ft. 9 in.)	S	Front Axle Centre to Artic Centre	1 363 mm	(4 ft. 5 in.)
D	Width over Tyres-23.5R25	2 926 mm	(9 ft. 7 in.)	T	Approach Angle	26°	
E	Tyre Track Width-23.5R25	2 325 mm	(7 ft. 8 in.)	V	Maximum Articulation Angle	45°	
F	Width over Tank / Bowser	2 840 mm	(9 ft. 4 in.)	W	Front Tie Down Height	1 092 mm	(3 ft. 7 in.)
G	Width over Mirrors - Operating Position	3 260 mm	(10 ft. 8 in.)	X1	Tank Lifting Centres	6 996 mm	(22 ft. 11 in.)
H	Ground Clearance - Artic	563 mm	(22.17 in.)	X2	Machine Lifting Centres	4 853 mm	(15 ft. 11 in.)
I	Ground Clearance - Front Axle	470 mm	(18.5 in.)	Y	Inner Turning Circle Radius - 23.5R25	3 475 mm	(11 ft. 5 in.)
K	Ground Clearance - Under Run Bar	N/A		Z	Outer Turning Circle Radius - 23.5R25	7 159 mm	(23 ft. 6 in.)
M	Tank / Bowser Length	3 368 mm	(11 ft. 1 in.)				

Gradeability/Rimpull

1. Determine tractive resistance by finding intersection of vehicle mass line and grade line. NOTE: 2% typical rolling resistance is already assumed in chart and grade line.
2. From this intersection, move straight right across charts until line intersects rimpull curve.
3. Read down from this point to determine maximum speed attained at that tractive resistance.

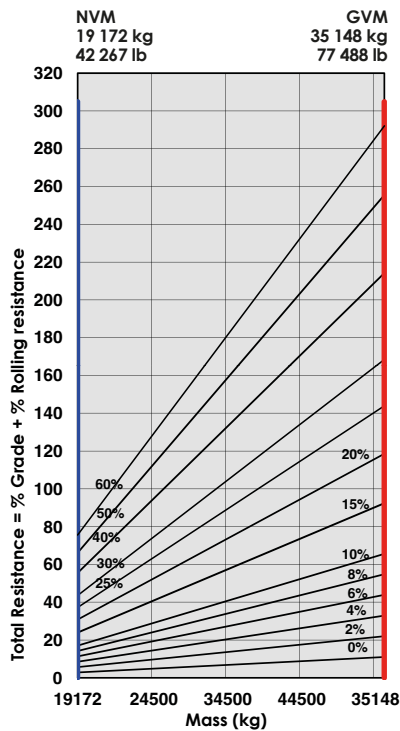

2806E 4x4 16 000 Ltr Water Tanker - Tractive Effort

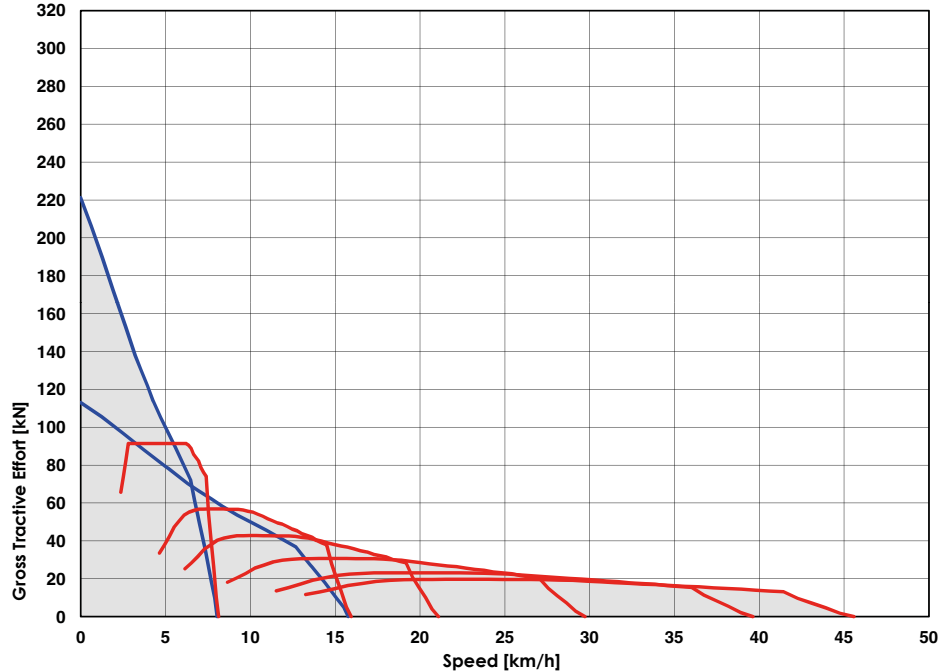

Retardation

1. Determine retardation force required by finding intersection of vehicle mass line.
2. From this intersection, move straight right across charts until line intersects the curve. NOTE: 2% typical rolling resistance is already assumed in chart.
3. Read down from this point to determine maximum speed.

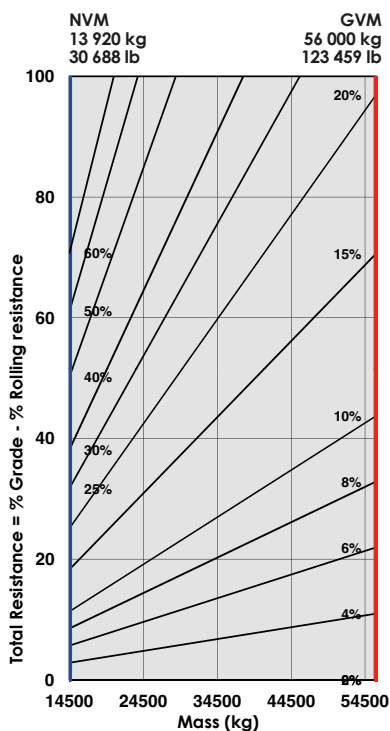

2806E 4x4 16 000 Ltr Water Tanker - Retardation

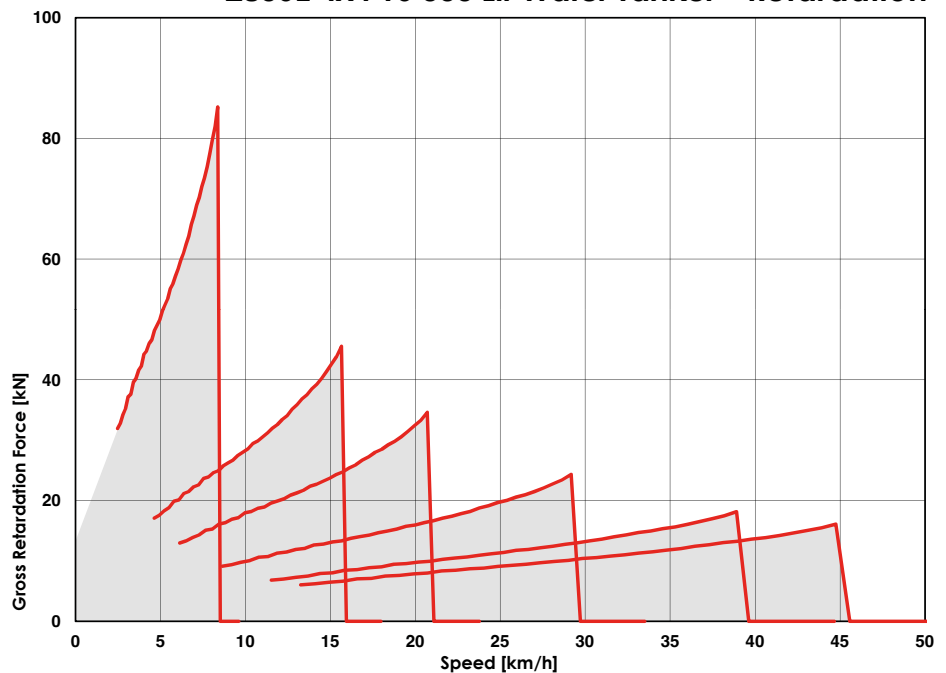

B18E 6x4 18 000 L Articulated Water Tanker

<p>ENGINE</p> <p>Manufacturer Mercedes Benz</p> <p>Model OM924LA</p> <p>Configuration Inline 4, turbocharged and intercooled.</p> <p>Net Power 163 kW (219 hp) @ 2 200 rpm in accordance with UN ECE R120</p> <p>Gross Torque 810 Nm (597 lbft) @ 1 200 -1 600 rpm</p> <p>Displacement 4,80 litres (293 cu.in)</p> <p>Auxiliary Brake Exhaust Valve Brake Engine Valve Brake</p> <p>Fuel Tank Capacity 195 litres (53 US gal)</p> <p>Certification OM924LA meets Euro III emissions regulations</p>	<p>TRANSFER CASE</p> <p>Manufacturer Kessler</p> <p>Series W1400</p> <p>Layout Remote mounted</p> <p>Gear Layout Three in-line helical gears</p> <p>Output Differential Interaxle 33/67 proportional differential. Automatic inter-axle differential lock.</p>	<p>99kW (133 hp) Maximum non-retarder. 505kW (677 hp) Maximum retarder.</p>	<p>RAISE TIME 10 s</p> <p>Lowering Time 5,5 s</p> <p>Tipping Angle 70° standard, or any lower angle programmable</p>																					
<p>TRANSMISSION</p> <p>Manufacturer Allison</p> <p>Model Standard Non Retarder: 3000P ORS Optional Retarder: 3000PR ORS</p> <p>Configuration Fully automatic planetary transmission with integral retarder.</p> <p>Layout Engine mounted</p> <p>Gear layout Constant meshing planetary gears, clutch operated</p> <p>Gears 6 Forward, 1 Reverse</p> <p>Clutch Type Hydraulically operated multidisc</p> <p>Control Type Electronic</p> <p>Torque Control Hydrodynamic with lock-up in all gears</p>	<p>AXLES</p> <p>Manufacturer Bell</p> <p>Model 15T</p> <p>Differential High input limited slip differential with spiral bevel gears.</p> <p>Final Drive Outboard heavy duty planetary on all axles</p>	<p>WHEELS</p> <p>Type Radial Earthmover</p> <p>Tyre 20.5 R 25</p>	<p>PNEUMATIC SYSTEM Air drier with heater and integral unloader valve, serving park brake and auxiliary functions.</p> <p>System Pressure 810 kPa (117 psi)</p>																					
<p>BRAKING SYSTEM</p> <p>Service Brake Dual circuit, full hydraulic actuation dry disc brakes with 8 calipers (4F, 2M, 2R).</p> <p>Maximum brake force: 244 kN (54 720 lbf)</p> <p>Park & Emergency Spring applied, air released driveline mounted disc.</p> <p>Maximum brake force: 182 kN (40 802 lbf)</p> <p>Auxiliary Brake Automatic exhaust valve brake and engine valve brake. Optional automatic, adjustable, integral, hydrodynamic transmission retarder. Output shaft speed dependant.</p> <p>Total Retardation Power 99kW (133 hp) Continuous non-retarder. 144kW (193 hp) Continuous retarder.</p>	<p>FRONT SUSPENSION Semi-independent, leading A-frame supported by hydro-pneumatic suspension struts.</p>	<p>REAR SUSPENSION Pivoting walking beams with laminated rubber suspension blocks</p>	<p>ELECTRICAL SYSTEM</p> <p>Voltage 24 V</p> <p>Battery Type Two AGM (Absorption Glass Mat) type</p> <p>Battery Capacity 2 X 75 Ah</p> <p>Alternator Rating 28 V 80 A</p>																					
<p>VEHICLE SPEEDS</p> <table border="1"> <tr><td>1st</td><td>11 km/h</td><td>7 mph</td></tr> <tr><td>2nd</td><td>20 km/h</td><td>12 mph</td></tr> <tr><td>3rd</td><td>27 km/h</td><td>17 mph</td></tr> <tr><td>4th</td><td>38 km/h</td><td>24 mph</td></tr> <tr><td>5th</td><td>50 km/h</td><td>31 mph</td></tr> <tr><td>6th</td><td>50 km/h</td><td>31 mph</td></tr> <tr><td>R</td><td>7 km/h</td><td>4 mph</td></tr> </table>	1st	11 km/h	7 mph	2nd	20 km/h	12 mph	3rd	27 km/h	17 mph	4th	38 km/h	24 mph	5th	50 km/h	31 mph	6th	50 km/h	31 mph	R	7 km/h	4 mph	<p>HYDRAULIC SYSTEM Full load sensing system serving the prioritized steering, body tipping and brake functions. A ground-driven, load sensing emergency steering pump is integrated into the main system.</p> <p>Pump Type Variable displacement load sensing piston</p> <p>Flow 155 l/min (41,5 gal/min)</p> <p>Pressure 27 MPa (3 915 psi)</p> <p>Filter 5 microns</p>	<p>STEERING SYSTEM Double-acting cylinders with ground driven emergency steering pump.</p> <p>Lock to lock turns 4,32</p> <p>Steering Angle 45°</p>	<p>WATER TANK</p> <p>Tank capacity 18 000 Litres</p>
1st	11 km/h	7 mph																						
2nd	20 km/h	12 mph																						
3rd	27 km/h	17 mph																						
4th	38 km/h	24 mph																						
5th	50 km/h	31 mph																						
6th	50 km/h	31 mph																						
R	7 km/h	4 mph																						
<p>WATER TANKER PLUMBING Centrifugal water pump</p> <p>Rate of Flow Standard: 1 800 L/min with 50 m head Option: 5 400 L/min with 70 m head</p>	<p>DUMPING SYSTEM Two double-acting, single stage, dump cylinders</p>	<p>CAB ROPS/FOPS certified 71 dBA internal sound level measured according to ISO 6396.</p>																						

Load Capacity & Ground Pressure

OPERATING WEIGHTS		GROUND PRESSURE		LOAD CAPACITY	
UNLADEN - Tare**		LADEN (No sinkage/Total Contact Area Method)		Rated Payload	18 000 litres (4 700 gallons)
	kg (lb)	20.5 R 25	kPa (Psi)		
Total	19 651 (43 323)	Front	236 (34,2)		
		Middle	310 (45)		
		Rear	310 (43)		
LADEN					
	kg (lb)				
Front	8 613 (18 988)				
Middle	14 453 (31 863)				
Rear	14 130 (31 151)				
Total	37 195 (82 001)				

Dimensions

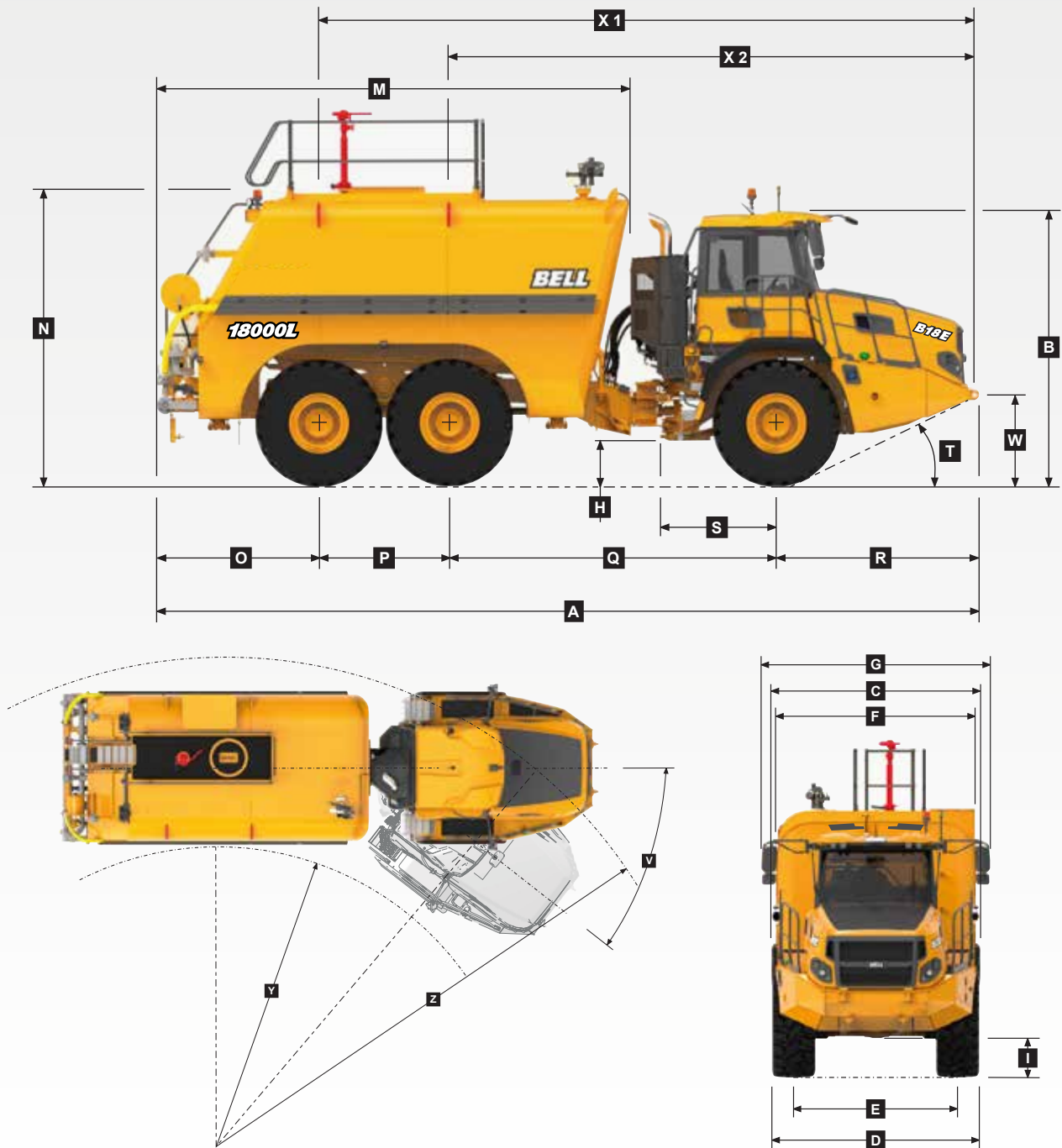

Machine Dimensions

A	Length - Transport Position	9 932 mm	(29 ft. 4 in.)	O	Rear Axle Centre to Bowser / Tank Rear	2 108 mm	(6 ft. 5 in.)
B	Height - Transport Position	3 454 mm	(11 ft. 3 in.)	P	Mid Axle to Rear Axle Centre	1 600 mm	(5 ft. 3 in.)
C	Width over Mudguards	2 568 mm	(9 ft. 9 in.)	Q	Mid Axle Centre to Front Axle Centre	3 865 mm	(14 ft. 5 in.)
D	Width over Tyres-23.5R25	2 550 mm	(9 ft. 7 in.)	R	Front Axle Centre to Machine Front	2 357 mm	(8 ft. 6 in.)
E	Tyre Track Width-23.5R25	2 022 mm	(7 ft. 8 in.)	S	Front Axle Centre to Artic Centre	1 361 mm	(4 ft. 5 in.)
F	Width over Tank / Bowser	2 491 mm	(9 ft. 4 in.)	T	Approach Angle	26°	
F	Width over Tank / Bowser (with hose)	2 570 mm	(10 ft. 8 in.)	V	Maximum Articulation Angle	45°	
G	Width over Mirrors - Operating Position	3 260 mm	(10 ft. 8 in.)	W	Front Tie Down Height	1 028 mm	(3 ft. 7 in.)
H	Ground Clearance - Artic	479 mm	(22.17 in.)	X1	Tank Lifting Centres	7 833 mm	(22 ft. 11 in.)
I	Ground Clearance - Front Axle	444 mm	(18.5 in.)	X2	Machine Lifting Centres	6 207 mm	(15 ft. 11 in.)
M	Tank / Bowser Length	5 624 mm	(11 ft. 1 in.)	Y	Inner Turning Circle Radius - 23.5R25	3 954 mm	(11 ft. 5 in.)
N	Maximum Tank Height	3 343 mm	(10 ft. 1 in.)	Z	Outer Turning Circle Radius - 23.5R25	7 309 mm	(23 ft. 6 in.)

Gradeability/Rimpull

1. Determine tractive resistance by finding intersection of vehicle mass line and grade line. NOTE: 2% typical rolling resistance is already assumed in chart and grade line.
2. From this intersection, move straight right across charts until line intersects rimpull curve.
3. Read down from this point to determine maximum speed attained at that tractive resistance.

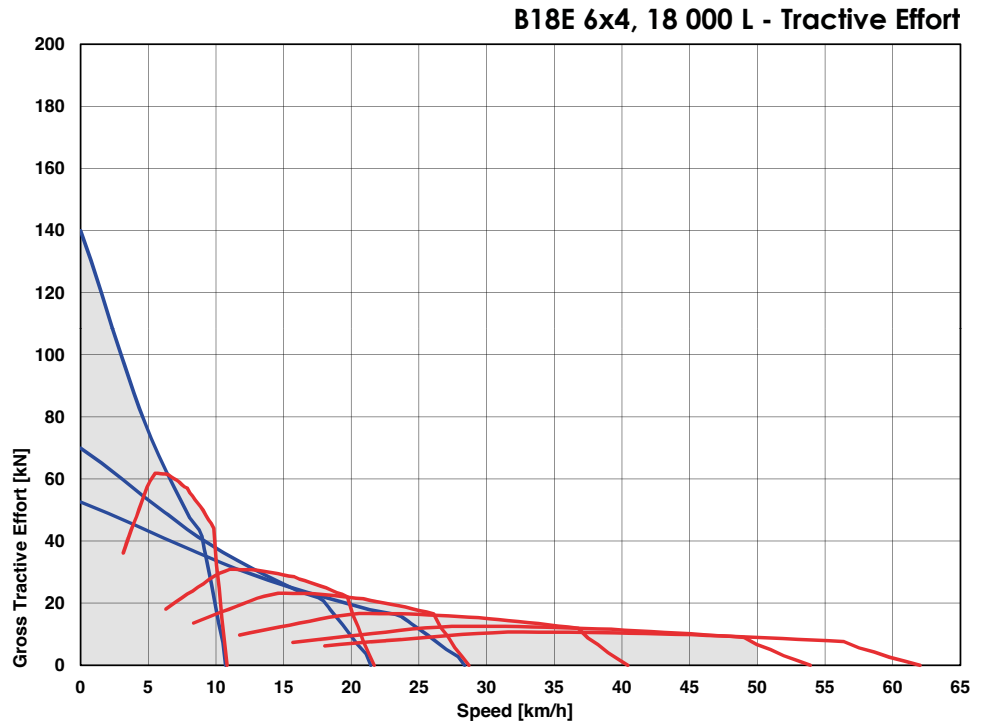
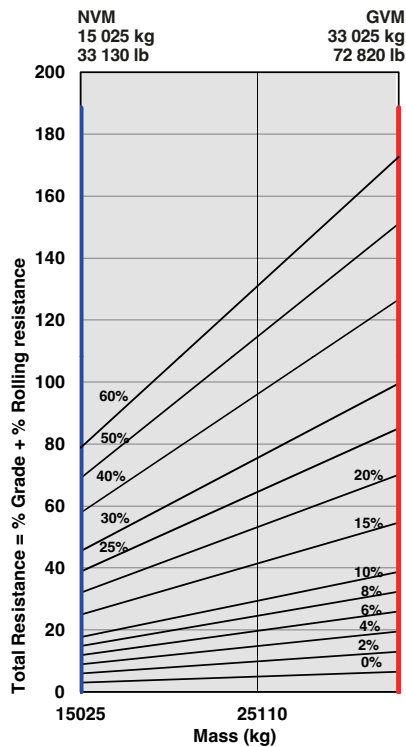

Retardation

1. Determine retardation force required by finding intersection of vehicle mass line.
2. From this intersection, move straight right across charts until line intersects the curve. NOTE: 2% typical rolling resistance is already assumed in chart.
3. Read down from this point to determine maximum speed.

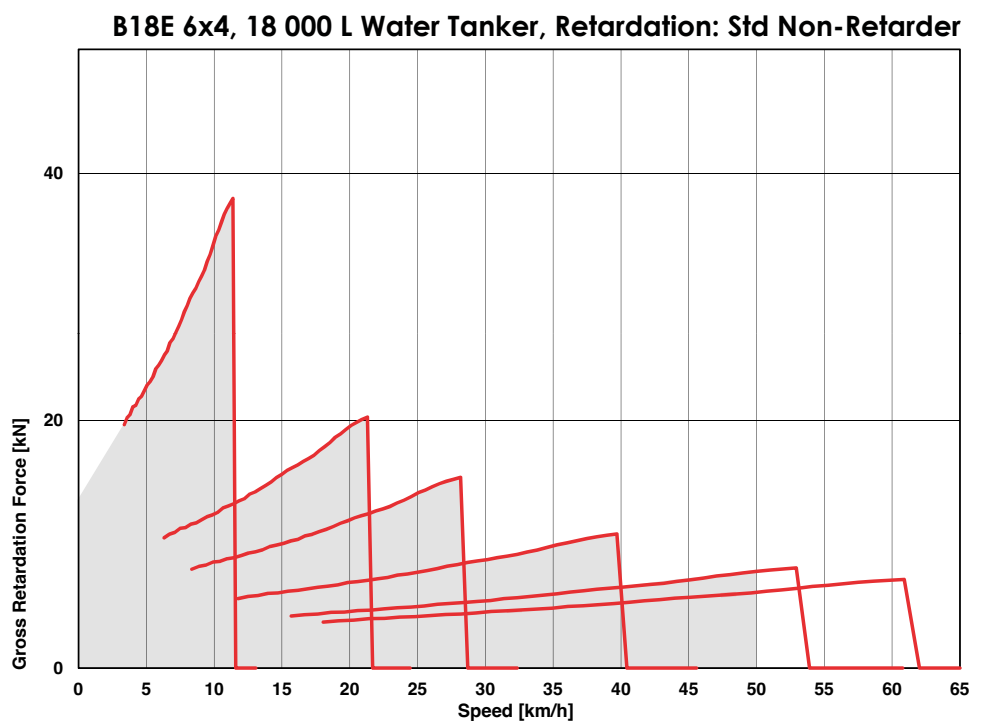
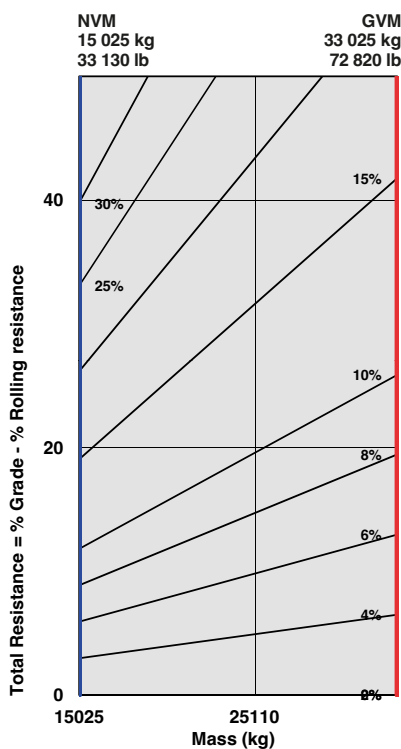

B25E 6x6 23 000 L Articulated Water Tanker

<p>ENGINE</p> <p>Manufacturer Mercedes Benz</p> <p>Model OM906LA</p> <p>Configuration Inline 6, turbocharged and intercooled.</p> <p>Net Power 205 kW (275 hp) @ 2 200 rpm in accordance with UN ECE R120</p> <p>Gross Torque 1 100 Nm (811 lbft) @ 1 200 -1 600 rpm</p> <p>Displacement 6,37 litres (389 cu.in)</p> <p>Auxiliary Brake Exhaust Valve Brake Engine Valve Brake</p> <p>Fuel Tank Capacity 379 litres (100 US gal)</p> <p>Certification OM906LA meets EU Stage II/EPA Tier 2 emissions regulations.</p>	<p>TRANSFER CASE</p> <p>Manufacturer Kessler</p> <p>Series W1400</p> <p>Layout Remote mounted</p> <p>Gear Layout Three in-line helical gears</p> <p>Output Differential Interaxle 33/67 proportional differential. Automatic inter-axle differential lock.</p>	<p>WHEELS</p> <p>Type Radial Earthmover</p> <p>Tyre 23.5 R 25</p>	<p>ELECTRICAL SYSTEM</p> <p>Voltage 24 V</p> <p>Battery Type Two AGM (Absorption Glass Mat) type</p> <p>Battery Capacity 2 X 75 Ah</p> <p>Alternator Rating 28 V 80 A</p>																					
<p>TRANSMISSION</p> <p>Manufacturer Allison</p> <p>Model 3500PR ORS</p> <p>Configuration Fully automatic planetary transmission with integral retarder.</p> <p>Layout Engine mounted</p> <p>Gear layout Constant meshing planetary gears, clutch operated</p> <p>Gears 6 Forward, 1 Reverse</p> <p>Clutch Type Hydraulically operated multi-disc</p> <p>Control Type Electronic</p> <p>Torque Control Hydrodynamic with lock-up in all gears.</p>	<p>AXLES</p> <p>Manufacturer Bell</p> <p>Model 15T</p> <p>Differential High input limited slip differential with spiral bevel gears.</p> <p>Final Drive Outboard heavy duty planetary on all axles</p>	<p>FRONT SUSPENSION</p> <p>Semi-independent, leading A-frame supported by hydro-pneumatic suspension struts</p> <p>REAR SUSPENSION</p> <p>Pivoting walking beams with laminated rubber suspension blocks</p> <p>HYDRAULIC SYSTEM</p> <p>Full load sensing system serving the prioritized steering, body tipping and brake functions. A ground-driven, load sensing emergency steering pump is integrated into the main system.</p> <p>Pump Type Variable displacement load sensing piston</p> <p>Flow 165 l/min (44 gal/min)</p> <p>Pressure 28 Mpa (4 061 psi)</p> <p>Filter 5 microns</p> <p>STEERING SYSTEM</p> <p>Double acting cylinders, with ground-driven emergency steering pump.</p> <p>Lock to lock turns 4,1</p> <p>Steering Angle 45°</p> <p>PNEUMATIC SYSTEM</p> <p>Air drier with heater and integral unloader valve, serving park brake and auxiliary functions.</p> <p>System Pressure 810 kPa (117 psi)</p>	<p>VEHICLE SPEEDS</p> <table border="1"> <tr><td>1st</td><td>7 km/h</td><td>4 mph</td></tr> <tr><td>2nd</td><td>15 km/h</td><td>9 mph</td></tr> <tr><td>3rd</td><td>23 km/h</td><td>14 mph</td></tr> <tr><td>4th</td><td>35 km/h</td><td>22 mph</td></tr> <tr><td>5th</td><td>47 km/h</td><td>29 mph</td></tr> <tr><td>6th</td><td>50 km/h</td><td>31 mph</td></tr> <tr><td>R</td><td>7 km/h</td><td>4 mph</td></tr> </table> <p>WATER TANK</p> <p>Tank capacity 23 000 Litres</p> <p>WATER TANKER PLUMBING</p> <p>Centrifugal water pump</p> <p>Rate of Flow Standard: 1 800 L/min with 50 m head Option: 5 400 L/min with 70 m head</p> <p>CAB</p> <p>ROPS/FOPS certified 72 dBA internal sound level measured according to ISO 6396.</p>	1st	7 km/h	4 mph	2nd	15 km/h	9 mph	3rd	23 km/h	14 mph	4th	35 km/h	22 mph	5th	47 km/h	29 mph	6th	50 km/h	31 mph	R	7 km/h	4 mph
1st	7 km/h	4 mph																						
2nd	15 km/h	9 mph																						
3rd	23 km/h	14 mph																						
4th	35 km/h	22 mph																						
5th	47 km/h	29 mph																						
6th	50 km/h	31 mph																						
R	7 km/h	4 mph																						

Load Capacity & Ground Pressure

OPERATING WEIGHTS		GROUND PRESSURE		LOAD CAPACITY	
UNLADEN		LADEN (No sinkage/Total Contact Area Method)			
	kg (lb)	23.5 R 25	kPa (Psi)	Rated Payload	23 000 litres (6 000 gallons)
Total	20 728 (45 697)	Front	267 (38,7)		
		Middle/Rear	357 (51,8)		
LADEN		Calculation method used by competition			
	kg (lb)				
Front	12 372 (27 276)	Front	131 (19)		
Middle	16 198 (35 710)	Middle/Rear	155 (22,5)		
Rear	16 158 (35 622)				
Total	44 728 (98 608)				

Dimensions

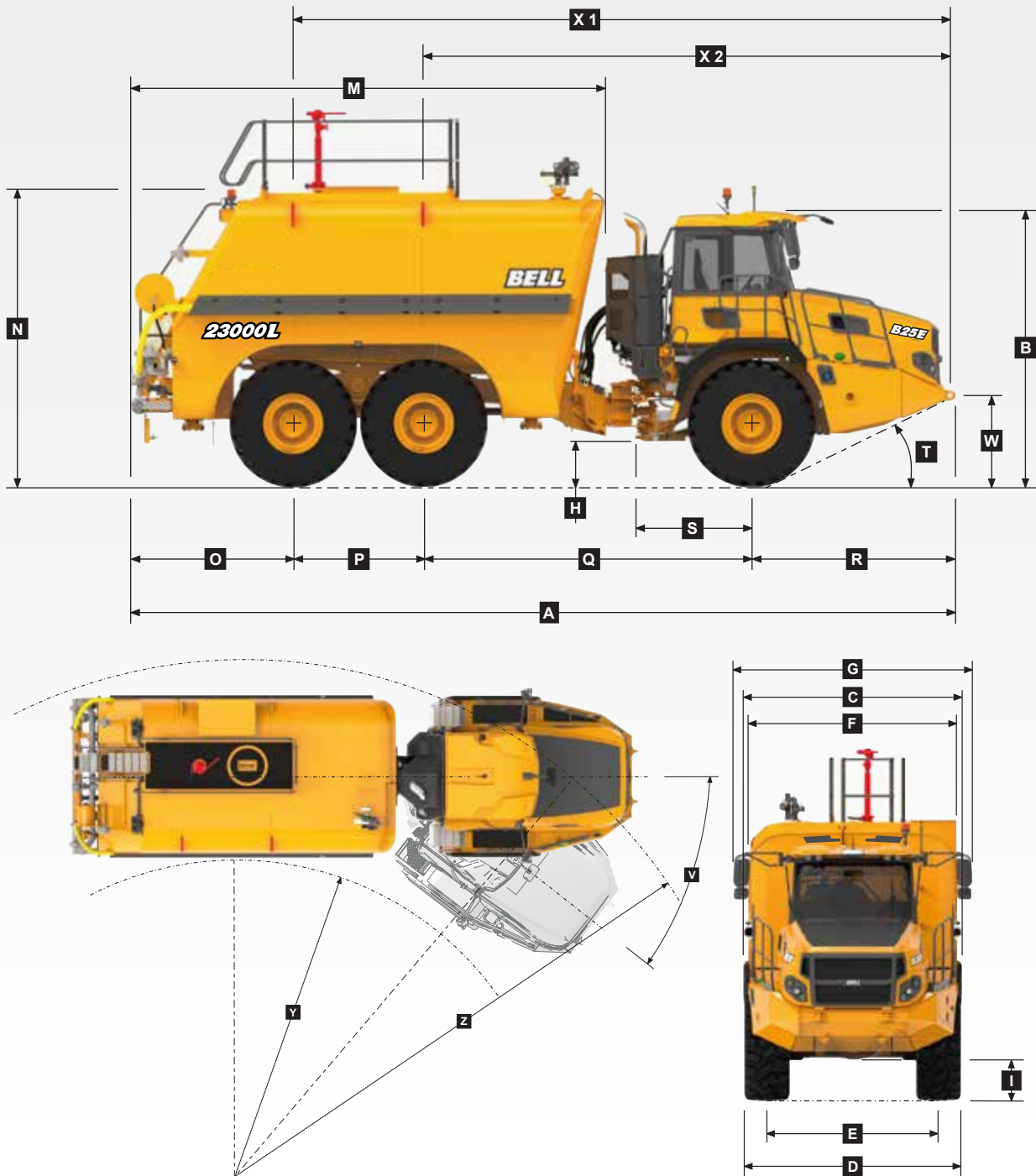

Machine Dimensions

A	Length - Transport Position	10355 mm	(34 ft. 6 in.)	O	Rear Axle Centre to Bowser / Tank Rear	2 072 mm	(6 ft. 10 in.)
B	Height - Transport Position	3 436 mm	(11 ft. 3 in.)	P	Mid Axle Centre to Rear Axle Centre	1 670 mm	(5 ft. 6 in.)
C	Width over Mudguards	2 985 mm	(9 ft. 6 in.)	Q	Mid Axle Centre to Front Axle Centre	4 181 mm	(13 ft. 9 in.)
D	Width over Tyres - 23.5R25	2 940 mm	(9 ft. 8 in.)	R	Front Axle Centre to Machine Front	2 602 mm	(8 ft. 9 in.)
E	Tyre Track Width - 23.5R25	2 356 mm	(7 ft. 9 in.)	S	Front Axle Centre to Artic Centre	1 362 mm	(4 ft. 65 in.)
F	Width over Tank / Bowser	2 855 mm	(9 ft. 4 in.)	T	Approach Angle	25°	
F	Width over Tank / Bowser (with hose)	3 005 mm	(9 ft. 4 in.)	V	Maximum Articulation Angle	45°	
G	Width over Mirrors - Operating Position	3 260 mm	(10 ft. 8 in.)	W	Front Tie Down Height	1 075 mm	(3 ft. 6 in.)
H	Ground Clearance - Artic	537 mm	(1 ft. 9 in.)	X1	Tank Lifting Centres	8 359 mm	(27 ft. 5 in.)
I	Ground Clearance - Front Axle	488 mm	(1 ft. 7 in.)	X2	Front Lifting Centre to Tank Lifting Centre	5 334 mm	(17 ft. 6 in.)
M	Tank / Bowser Length	6 020 mm	(19 ft. 9 in.)	Y	Inner Turning Circle Radius - 23.5R25	4 110 mm	(13 ft. 6 in.)
N	Maximum Tank Height	3 510 mm	(12 ft. 8 in.)	Z	Outer Turning Circle Radius - 23.5R25	8 000 mm	(26 ft. 3 in.)

Gradeability/Rimpull

1. Determine tractive resistance by finding intersection of vehicle mass line and grade line. NOTE: 2% typical rolling resistance is already assumed in chart and grade line.
2. From this intersection, move straight right across charts until line intersects rimpull curve.
3. Read down from this point to determine maximum speed attained at that tractive resistance.

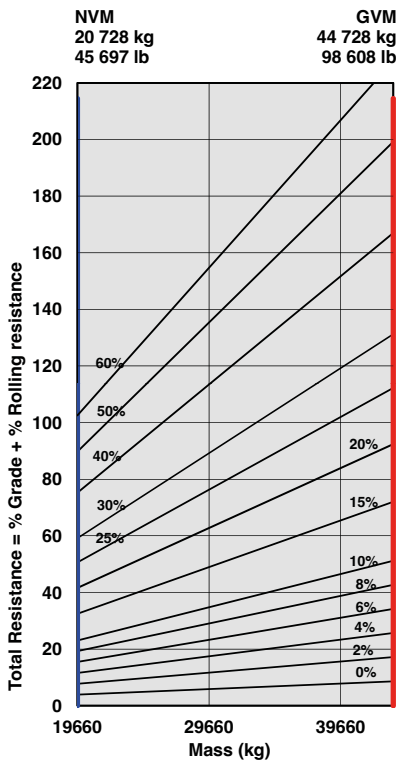

B25E 6x6, 23 000 L Water Tanker - Tractive Effort

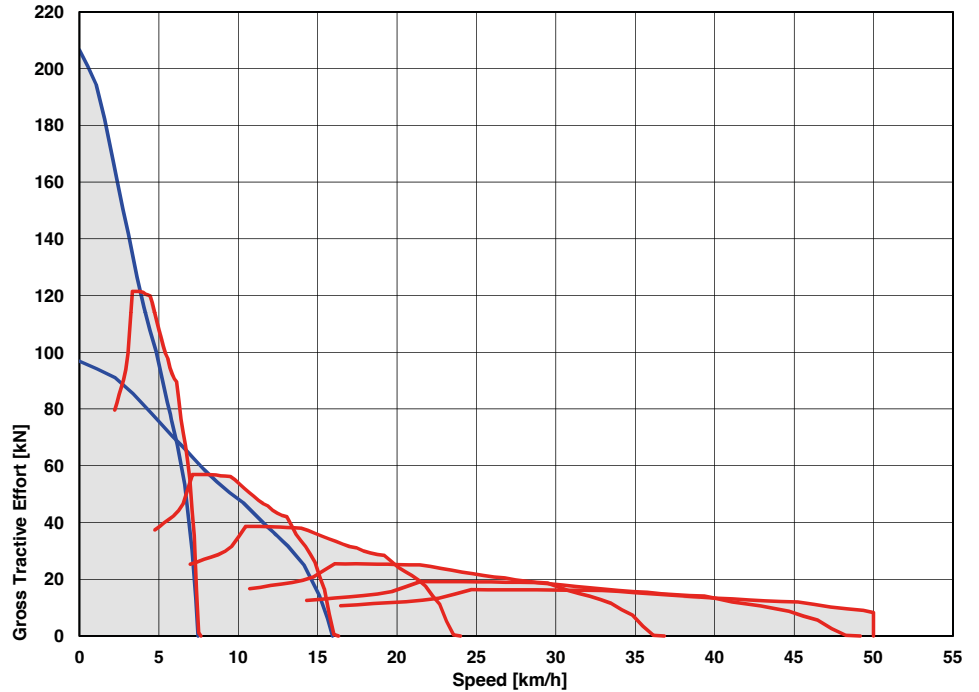

Retardation

1. Determine retardation force required by finding intersection of vehicle mass line.
2. From this intersection, move straight right across charts until line intersects the curve. NOTE: 2% typical rolling resistance is already assumed in chart.
3. Read down from this point to determine maximum speed.

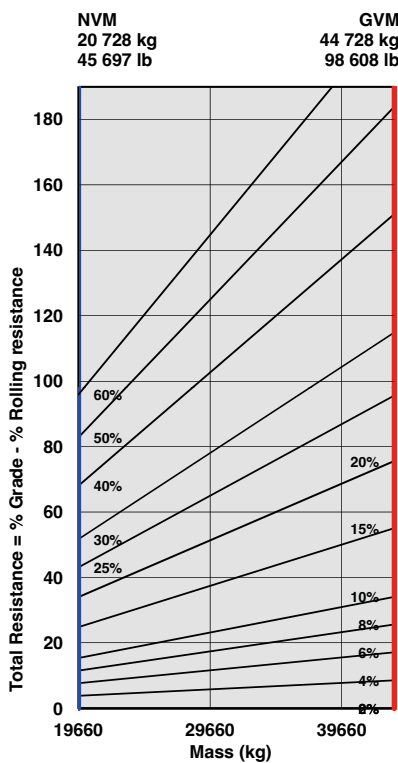

B25E, 23 000 L Water Tanker - Retardation

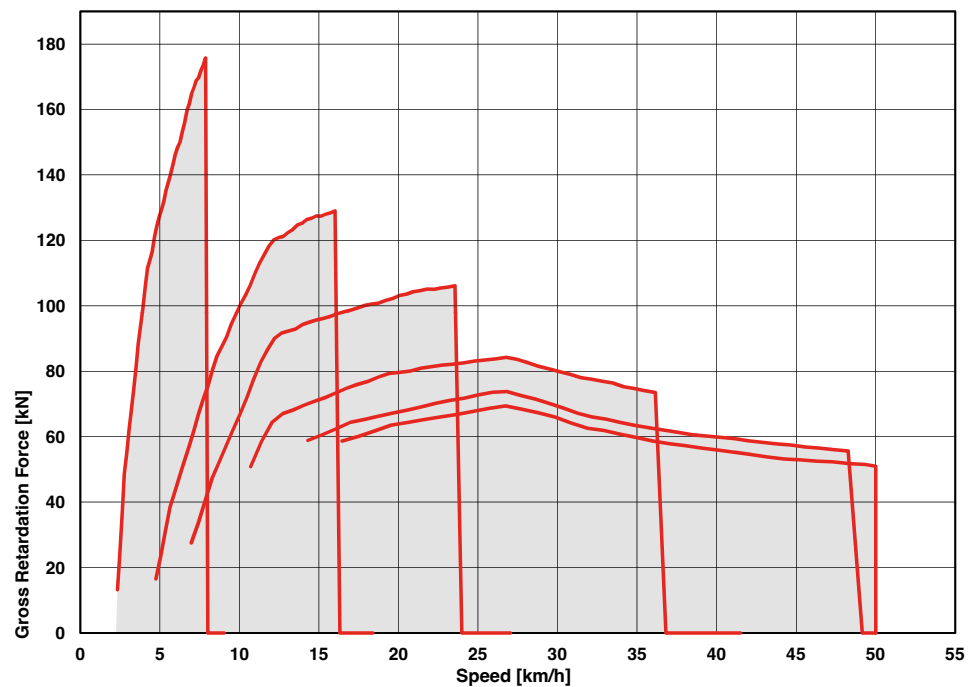

B30E 6x6 27 000 L Articulated Water Truck

ENGINE

Manufacturer
Mercedes Benz

Model
OM926LA

Configuration
Inline 6, turbocharged and intercooled.

Net Power
240 kW (322 hp) @ 2 200 rpm in accordance with UN ECE R120

Gross Torque
1 300 Nm (959 lbf) @ 1 200 -1 600 rpm

Displacement
7,2 litres (439 cu.in)

Auxiliary Brake
Exhaust Valve Brake
Engine Valve Brake

Fuel Tank Capacity
379 litres (100 US gal)

Certification
OM926LA meets EU Stage II/EPA Tier 2 emissions regulations.

TRANSMISSION

Manufacturer
Allison

Model
3400P ORS

Configuration
Fully automatic planetary transmission

Layout
Engine mounted

Gear layout
Constant meshing planetary gears, clutch operated

Gears
6 Forward, 1 Reverse

Clutch Type
Hydraulically operated multi-disc

Control Type
Electronic

Torque Control
Hydrodynamic with lock-up in all gears.

TRANSFER CASE

Manufacturer
Kessler

Series
W1400

Layout
Remote mounted

Gear Layout
Three in-line helical gears

Output Differential
Interaxle 33/67 proportional differential. Automatic inter-axle differential lock.

AXLES

Manufacturer
Bell

Model
18T

Differential
High input limited slip differential with spiral bevel gears.

Final Drive
Outboard heavy duty planetary on all axles

BRAKING SYSTEM

Service Brake
Dual circuit, full hydraulic actuation wet disc brakes on front and middle axles. Wet brake oil is circulated through a filtration and cooling system.

Maximum brake force:
187 kN (42 000 lbf)

Park & Emergency
Spring applied, air released driveline mounted disc.

Maximum brake force:
251 kN (56 400 lbf)

Auxiliary Brake
Automatic engine valve brake. Automatic retardation through electronic activation of wet brake system.

Total Retardation Power
265 kW (355 hp) Continuous
494 kW (662 hp) Maximum

WHEELS

Type
Radial Earthmover

Tyre
23.5 R 25

FRONT SUSPENSION

Semi-independent, leading A-frame supported by hydro-pneumatic suspension struts.

REAR SUSPENSION

Pivoting walking beams with laminated rubber suspension blocks

HYDRAULIC SYSTEM

Full load sensing system serving the prioritized steering, body tipping and brake functions. A ground-driven, load sensing emergency steering pump is integrated into the main system.

Pump Type
Variable displacement load sensing piston.

Flow
165 l/min (44 gal/min)

Pressure
28 Mpa (4 061 psi)

Filter
5 microns

STEERING SYSTEM

Double acting cylinders, with ground-driven emergency steering pump.

Lock to lock turns
4,1

Steering Angle
45°

PNEUMATIC SYSTEM

Air drier with heater and integral unloader valve, serving park brake and auxiliary functions.

System Pressure
810 kPa (117 psi)

ELECTRICAL SYSTEM

Voltage
24 V

Battery Type
Two AGM (Absorption Glass Mat) type

Battery Capacity
2 X 75 Ah

Alternator Rating
28 V 80 A

VEHICLE SPEEDS

1st	8 km/h	5 mph
2nd	14 km/h	9 mph
3rd	20 km/h	12 mph
4th	29 km/h	18 mph
5th	43 km/h	26 mph
6th	50 km/h	31 mph
R	8 km/h	5 mph

WATER TANK

Tank capacity
27 000 Litres

WATER TANKER PLUMBING

Centrifugal water pump

Rate of Flow
Standard:
1 800 L/min with 50 m head

Option:
5 400 L/min with 70 m head

CAB

ROPS/FOPS certified 72 dBA internal sound level measured according to ISO 6396.

Load Capacity & Ground Pressure

OPERATING WEIGHTS		GROUND PRESSURE		LOAD CAPACITY	
UNLADEN		LADEN (No sinkage/Total Contact Area Method)			
	kg (lb)	23.5 R 25	kPa (Psi)	Rated Payload	27 000 litres
Total	24 082 (53 091)	Front	298 (43,2)		(7 100 gallons)
		Middle/ Rear	405 (58,7)		
LADEN		Calculation method used by competition			
	kg (lb)	Front	134 (19,4)		
Front	14 323 (31 577)	Middle/ Rear	169 (24,5)		
Middle	18 509 (40 805)				
Rear	18 053 (39 800)				
Total	50 885 (112 182)				

Dimensions

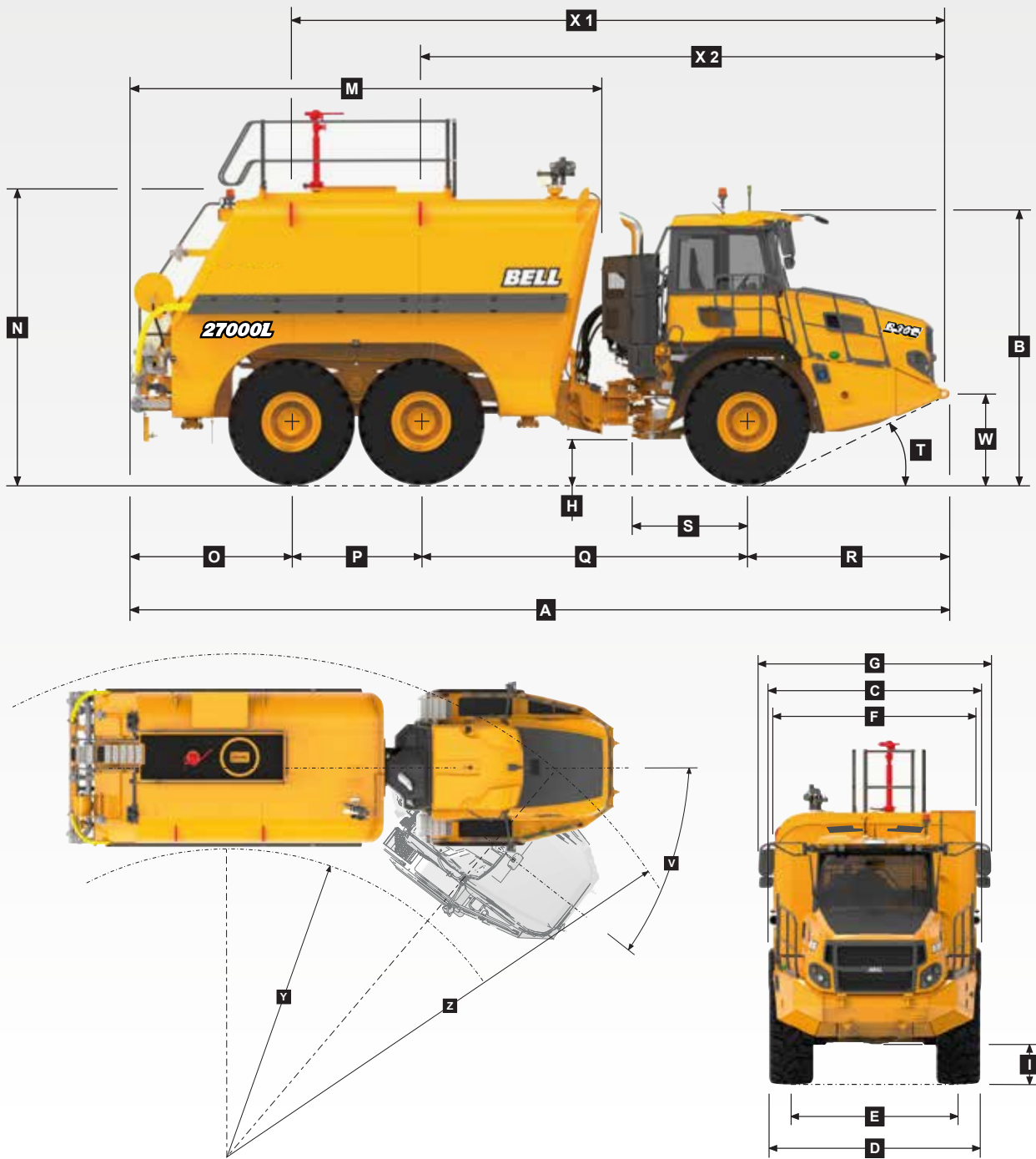

Machine Dimensions

A	Length - Transport Position	10 525 mm	(34 ft. 6 in.)	P	Mid Axle Centre to Rear Axle Centre	1 670 mm	(5 ft. 6 in.)
B	Height - Transport Position	3 436 mm	(11 ft. 3 in.)	Q	Mid Axle Centre to Front Axle Centre	4 181 mm	(13 ft. 9 in.)
C	Width over Mudguards	2 985 mm	(9 ft. 6 in.)	R	Front Axle Centre to Machine Front	2 602 mm	(8 ft. 9 in.)
D	Width over Tyres - 23.5R25	2 940 mm	(9 ft. 8 in.)	S	Front Axle Centre to Artic Centre	1 362 mm	(4 ft. 65 in.)
E	Tyre Track Width - 23.5R25	2 356 mm	(7 ft. 9 in.)	T	Approach Angle	25°	
F	Width over Tank / Bowser	2 855 mm	(9 ft. 4 in.)	V	Maximum Articulation Angle	45°	
G	Width over Mirrors - Operating Position	3 260 mm	(10 ft. 8 in.)	W	Front Tie Down Height	1 075 mm	(3 ft. 6 in.)
H	Ground Clearance - Artic	537 mm	(1 ft. 9 in.)	X1	Tank Lifting Centres	8 359 mm	(27 ft. 5 in.)
I	Ground Clearance - Front Axle	488 mm	(1 ft. 7 in.)	X2	Front Lifting Centre to Tank Lifting Centre	5 334 mm	(17 ft. 6 in.)
M	Tank / Bowser Length	6 030 mm	(19 ft. 9 in.)	Y	Inner Turning Circle Radius - 23.5R25	4 110 mm	(13 ft. 6 in.)
N	Maximum Tank Height	3 780 mm	(12 ft. 8 in.)	Z	Outer Turning Circle Radius - 23.5R25	8 000 mm	(26 ft. 3 in.)
O	Rear Axle Centre to Bowser / Tank Rear	2 072 mm	(6 ft. 10 in.)				

Gradeability/Rimpull

1. Determine tractive resistance by finding intersection of vehicle mass line and grade line. NOTE: 2% typical rolling resistance is already assumed in chart and grade line.
2. From this intersection, move straight right across charts until line intersects rimpull curve.
3. Read down from this point to determine maximum speed attained at that tractive resistance.

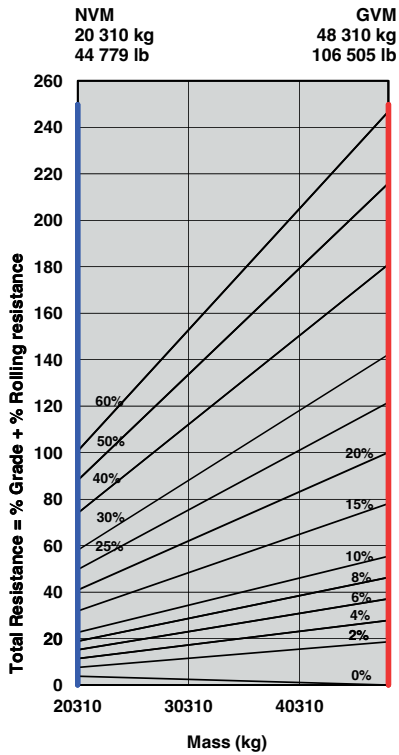

B30E 6x6 27 000 Ltr Water Tanker - Tractive Effort

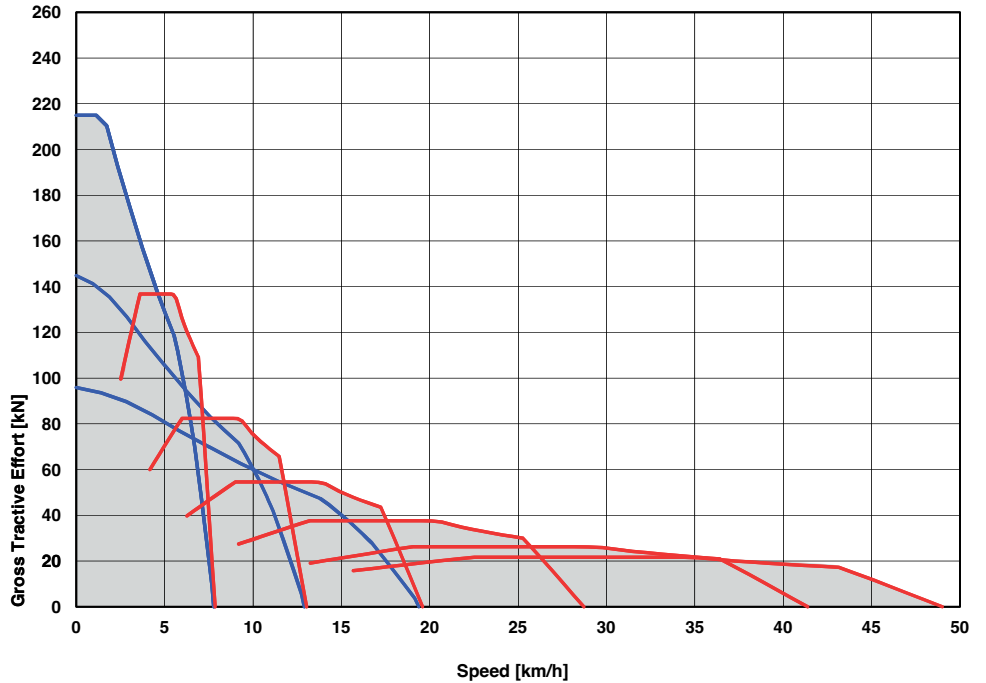

Retardation

1. Determine retardation force required by finding intersection of vehicle mass line.
2. From this intersection, move straight right across charts until line intersects the curve. NOTE: 2% typical rolling resistance is already assumed in chart.
3. Read down from this point to determine maximum speed.

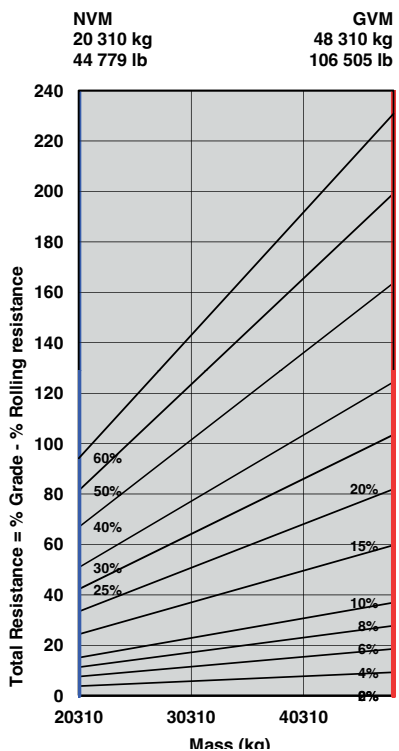

B30E 6x6 27 000 Ltr Water Tanker - Retardation

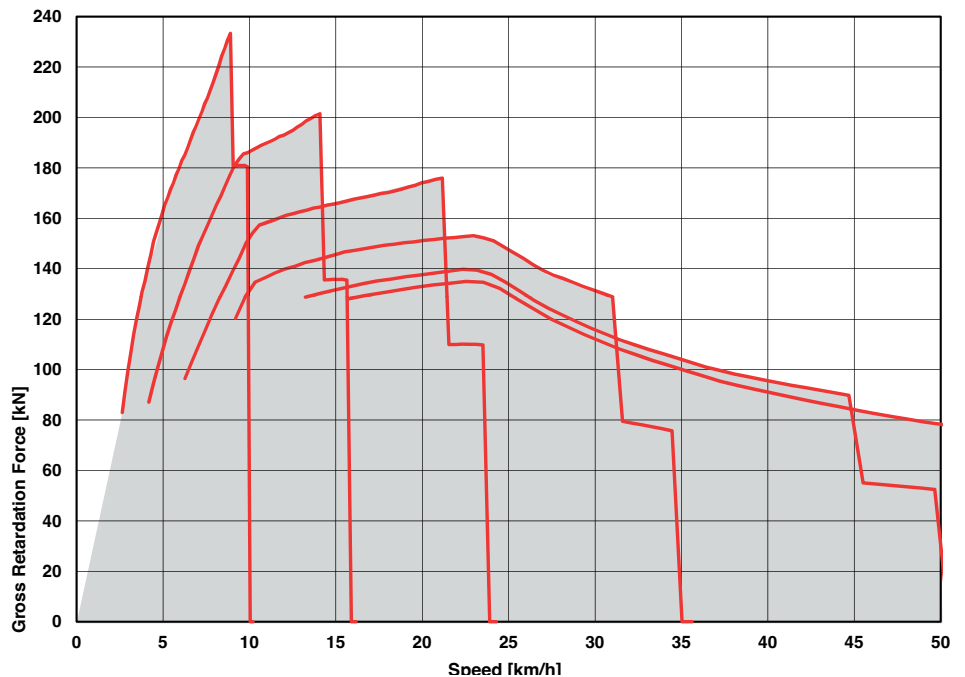

B40E 6x6 35 000 L Articulated Water Truck

ENGINE Manufacturer Mercedes Benz (MTU) Model OM471LA (MTU 6R 1300) Configuration Inline 6, turbocharged and intercooled Net Power 380 kW (510 hp) @ 1 600 rpm Gross Torque 2 600 Nm (1 918 lbft) @ 1 300 rpm Displacement 12,8 litres (781 cu.in) Auxiliary Brake Jacobs Engine Brake® Fuel Tank Capacity 533 litres (140.8 US gal) Certification OM471LA (MTU 6R 1300) is EU Stage IIIA / EPA Tier 3 emission level equivalent	TRANSFER CASE Manufacturer Kessler Model W2400 Layout Remote mounted Gear Layout Three in-line helical gears Output Differential Interaxle 29/71 proportional differential. Automatic inter-axle differential lock.	WHEELS Type Radial Earthmover Tyre 29.5 R 25 (875/65 R 29 optional)	PNEUMATIC SYSTEM Air drier with heater and integral unloader valve, serving park brake and auxiliary functions System Pressure 810 kPa (117 psi)																								
TRANSMISSION Manufacturer Allison Model 4700 ORS Configuration Fully automatic planetary transmission Layout Engine mounted Gear Layout Constant meshing planetary gears, clutch operated Gears 7 Forward, 1 reverse Clutch Type Hydraulically operated multi-disc Control Type Electronic Torque Control Hydrodynamic with lock-up in all gears	AXLES Manufacturer Bell Model 30T Differential High input controlled traction differential with spiral bevel gears Final Drive Outboard heavy duty planetary on all axles	FRONT SUSPENSION Semi-independent, leading A-frame supported by hydro-pneumatic suspension struts Option: Electronically controlled adaptive suspension with ride height adjustment REAR SUSPENSION Pivoting walking beams with laminated rubber suspension blocks Option: Comfort Ride suspension walking beams, with two-stage sandwich block	ELECTRIC SYSTEM Voltage 24 V Battery Type Two AGM (Absorption Glass Mat) type Battery Capacity 2 X 75 Ah Alternator Rating 28V 80A																								
	BRAKING SYSTEM Service Brake Dual circuit, full hydraulic actuation wet disc brakes on front and middle axles. Wet brake oil is circulated through a filtration and cooling system. Maximum brake force: 305 kN (68 567 lbf) Park & Emergency Spring applied, air released driveline mounted disc Maximum brake force: 218 kN (49 008 lbf) Auxiliary Brake Jacobs Engine Brake®. Automatic retardation through electronic activation of wet brake system. Total Retardation Power Continuous: 442 kW (593 hp) Maximum: 854 kW (1 145 hp)	HYDRAULIC SYSTEM Full load sensing system serving the prioritised steering, body tipping and brake functions. A ground-driven, load sensing emergency steering pump is integrated into the main system. Pump Type Variable displacement load sensing piston Flow 330 L/min (87 gal/min) Pressure 315 Bar (4 569 psi) Filter 5 microns	MAX VEHICLE SPEED <table border="1"> <tr><td>1st</td><td>4 km/h</td><td>2,5 mph</td></tr> <tr><td>2nd</td><td>9 km/h</td><td>6 mph</td></tr> <tr><td>3rd</td><td>17 km/h</td><td>11 mph</td></tr> <tr><td>4th</td><td>23 km/h</td><td>14 mph</td></tr> <tr><td>5th</td><td>33 km/h</td><td>21 mph</td></tr> <tr><td>6th</td><td>44 km/h</td><td>27,3 mph</td></tr> <tr><td>7th</td><td>51 km/h</td><td>32 mph</td></tr> <tr><td>R</td><td>7 km/h</td><td>4 mph</td></tr> </table>	1st	4 km/h	2,5 mph	2nd	9 km/h	6 mph	3rd	17 km/h	11 mph	4th	23 km/h	14 mph	5th	33 km/h	21 mph	6th	44 km/h	27,3 mph	7th	51 km/h	32 mph	R	7 km/h	4 mph
1st	4 km/h	2,5 mph																									
2nd	9 km/h	6 mph																									
3rd	17 km/h	11 mph																									
4th	23 km/h	14 mph																									
5th	33 km/h	21 mph																									
6th	44 km/h	27,3 mph																									
7th	51 km/h	32 mph																									
R	7 km/h	4 mph																									
		STEERING SYSTEM Double acting cylinders, with ground-driven emergency steering pump Lock to lock turns 5 Steering Angle 42°	WATER TANK Tank capacity 35 000 Litres																								
			WATER TANKER PLUMBING Centrifugal water pump Rate of Flow 5 400 L/min Head 70 m																								
			CAB ROPS/FOPS certified 76 dBA internal sound level measured according to ISO 6396																								

Load Capacity & Ground Pressure

OPERATING WEIGHTS		GROUND PRESSURE		LOAD CAPACITY	
UNLADEN		LADEN (No sinkage/Total Contact Area Method)			
	kg (lb)	29.5 R 25 (kPa/Psi)	875/65 R29 (kPa/Psi)		
Total	34 596 (76 271)	Front: 310 (45)	Front: 293 (42,5)	Rated Payload	35 000 litres (9 250 gallons)
		Mid/Rear: 367 (53,2)	Mid/Rear: 329 (47,7)		
LADEN		Calculation method used by competition			
	kg (lb)	29.5 R 25 (kPa/Psi)	875/65 R29 (kPa/Psi)		
Front	21 691 (47 820)	Front: 151 (21,9)	Front: 131 (19)		
Middle	26 059 (57 450)	Mid/Rear: 169 (24,5)	Mid/Rear: 149 (21,6)		
Rear	25 846 (56 981)				
Total	73 596 (162 251)				

Dimensions

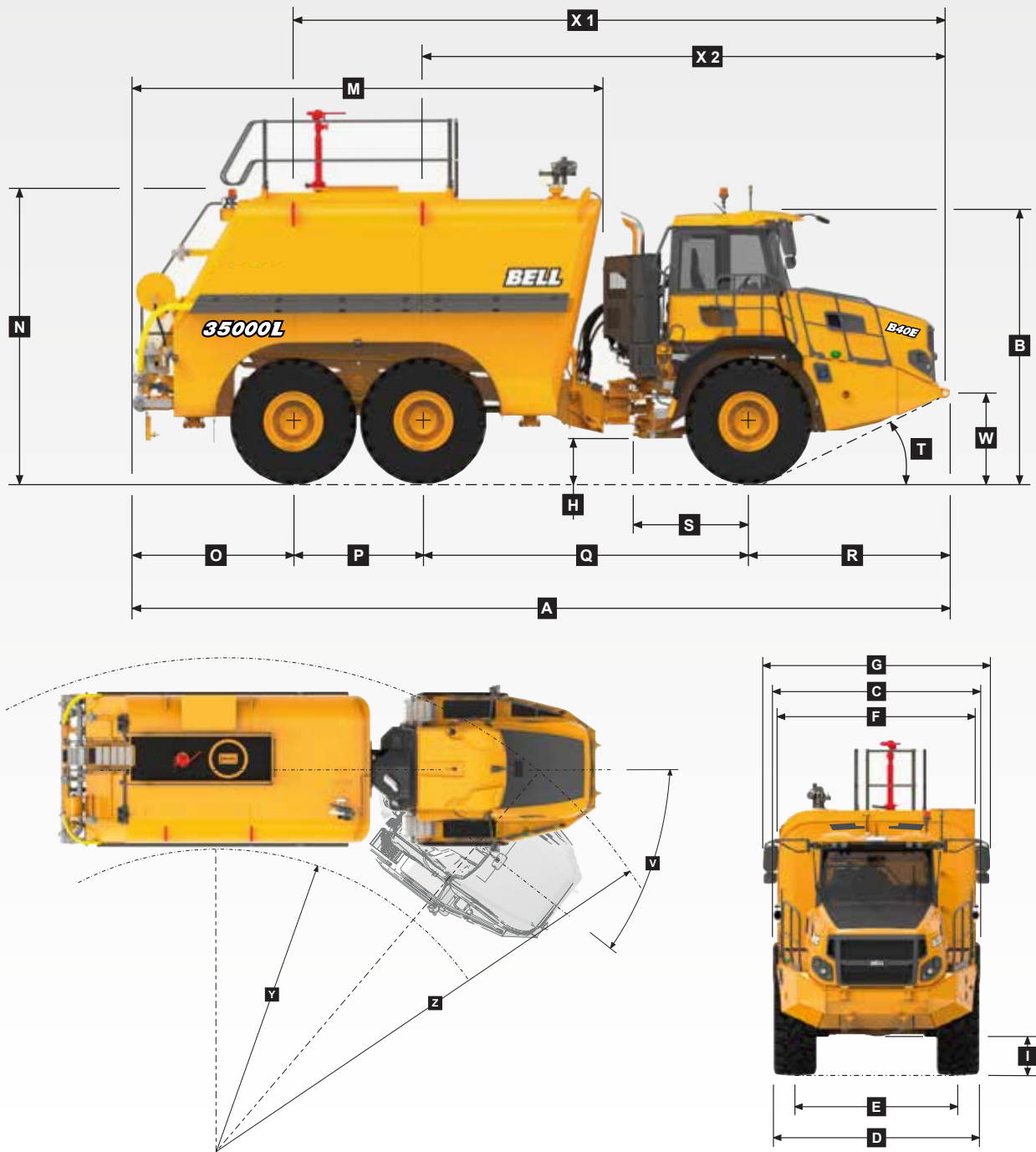

Machine Dimensions

A	Length - Transport Position	12 084 mm	(39 ft. 8 in.)	O	Rear Axle Centre to Bowser / Tank Rear	2 443 mm	(8 ft. 0 in.)
B	Height - Transport Position	3 802 mm	(12 ft. 6 in.)	P	Mid Axle Centre to Rear Axle Centre	1 950 mm	(6 ft. 5 in.)
C	Width over Mudguards	3 495 mm	(11 ft. 6 in.)	Q	Mid Axle Centre to Front Axle Centre	4 438 mm	(14 ft. 7 in.)
D	Width over Tyres - 875/65 R29	3 656 mm	(11 ft. 12 in.)	R	Front Axle Centre to Machine Front	3 255 mm	(10 ft. 8 in.)
D	Tyre Track Width - 29.5R25	3 487 mm	(11 ft. 5 in.)	S	Front Axle Centre to Artic Centre	1 558 mm	(5 ft. 1 in.)
E	Tyre Track Width - 875/65 R29	2 773 mm	(9 ft. 1 in.)	T	Approach Angle	24°	
E	Tyre Track Width - 29.5R25	2 725 mm	(8 ft. 11 in.)	V	Maximum Articulation Angle	42°	
F	Width over Tank / Bowser	3 379 mm	(11 ft. 1 in.)	W	Front Tie Down Height	1 265 mm	(4 ft. 2 in.)
F	Width over Tank / Bowser (with hose)	3 529 mm	(11 ft. 5 in.)	X1	Tank Lifting Centres	10 023 mm	(32 ft. 10 in.)
G	Width over Mirrors - Operating Position	3 614 mm	(11 ft. 10 in.)	X2	Front Lifting Centres to Tank Lifting Centre	7 173 mm	(23 ft. 6 in.)
H	Ground Clearance - Artic	545 mm	(1 ft. 9 in.)	Y	Inner Turning Circle Radius - 875/65 R29	4 782 mm	(15 ft. 8 in.)
I	Ground Clearance - Front Axle	545 mm	(1 ft. 9 in.)	Y	Inner Turning Circle Radius - 29.5R25	4 866 mm	(15 ft. 12 in.)
M	Tank / Bowser Length	6 797 mm	(22 ft. 4 in.)	Z	Outer Turning Circle Radius - 875/65 R29	9 320 mm	(30 ft. 7 in.)
N	Maximum Tank Height	4 002 mm	(13 ft. 2 in.)	Z	Outer Turning Circle Radius - 29.5R25	9 235 mm	(30 ft. 4 in.)

Gradeability/Rimpull

1. Determine tractive resistance by finding intersection of vehicle mass line and grade line. NOTE: 2% typical rolling resistance is already assumed in chart and grade line.
2. From this intersection, move straight right across charts until line intersects rimpull curve.
3. Read down from this point to determine maximum speed attained at that tractive resistance.

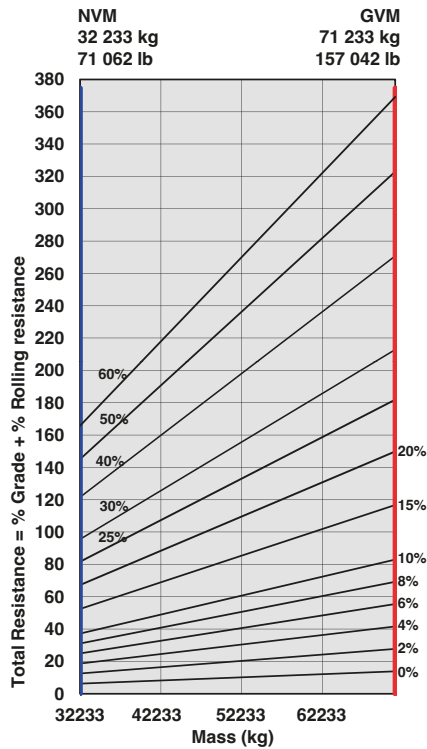

B40E 6x6, 35 000 Ltr Water Tanker - Tractive Effort

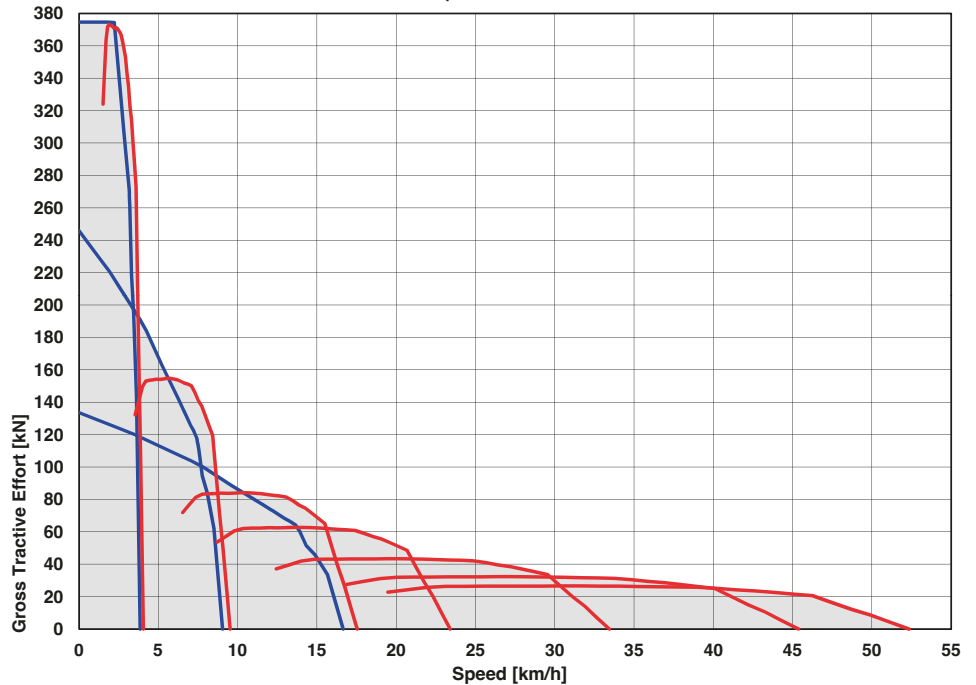

Retardation

1. Determine retardation force required by finding intersection of vehicle mass line.
2. From this intersection, move straight right across charts until line intersects the curve. NOTE: 2% typical rolling resistance is already assumed in chart.
3. Read down from this point to determine maximum speed.

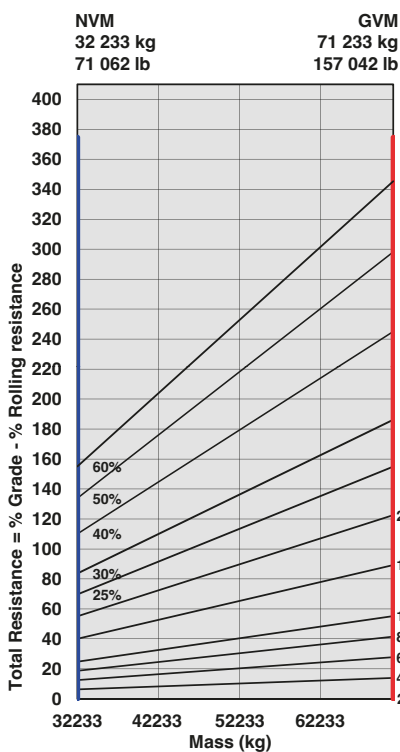

B40E 6x6, 35 000 Ltr Water Tanker - Retardation

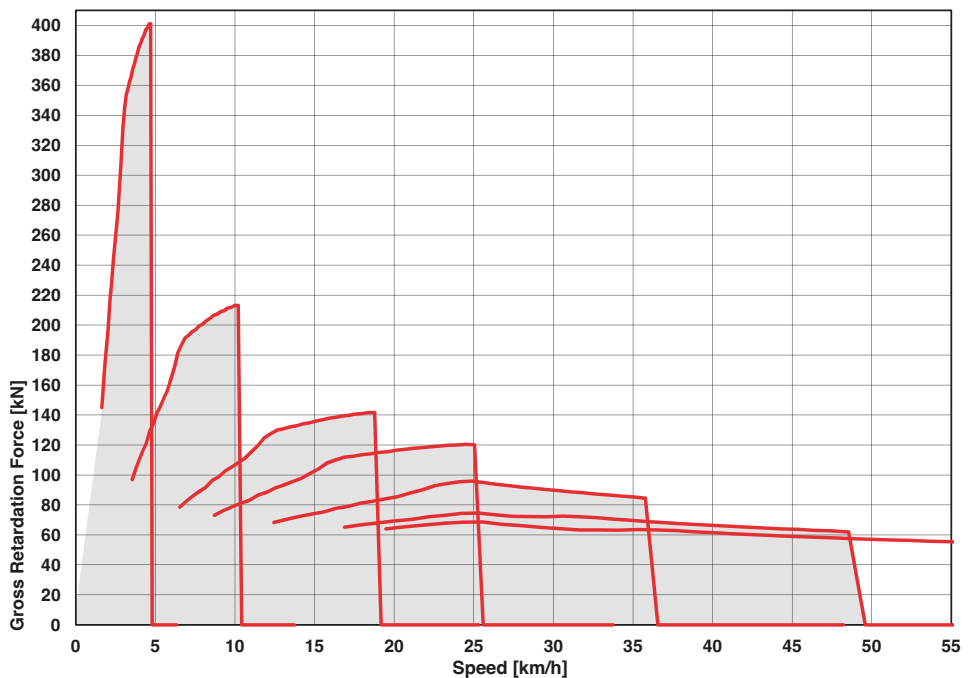

B45E 6x6 38 000 L Articulated Water Truck

<p>ENGINE</p> <p>Manufacturer Mercedes Benz (MTU)</p> <p>Model OM471LA (MTU 6R 1300)</p> <p>Configuration Inline 6, turbocharged and intercooled</p> <p>Net Power 390 kW (523 hp) @ 1 600 rpm</p> <p>Gross Torque 2 600 Nm (1 918 lbf) @ 1 300 rpm</p> <p>Displacement 12,8 litres (781 cu.in)</p> <p>Auxiliary Brake Jacobs Engine Brake®</p> <p>Fuel Tank Capacity 533 litres (140.8 US gal)</p> <p>Certification OM471LA (MTU 6R 1300) is EU Stage IIIA / EPA Tier 3 emission level equivalent</p>	<p>TRANSFER CASE</p> <p>Manufacturer Kessler</p> <p>Model W2400</p> <p>Layout Remote mounted</p> <p>Gear Layout Three in-line helical gears</p> <p>Output Differential Interaxle 29/71 proportional differential. Automatic inter-axle differential lock.</p>	<p>WHEELS</p> <p>Type Radial Earthmover</p> <p>Tyre 29.5 R 25 (875/65 R 29 optional)</p>	<p>PNEUMATIC SYSTEM</p> <p>Air drier with heater and integral unloader valve, serving park brake and auxiliary functions</p> <p>System Pressure 810 kPa (117 psi)</p>																								
<p>TRANSMISSION</p> <p>Manufacturer Allison</p> <p>Model 4700 ORS</p> <p>Configuration Fully automatic planetary transmission</p> <p>Layout Engine mounted</p> <p>Gear Layout Constant meshing planetary gears, clutch operated</p> <p>Gears 7 Forward, 1 reverse</p> <p>Clutch Type Hydraulically operated multi-disc</p> <p>Control Type Electronic</p> <p>Torque Control Hydrodynamic with lock-up in all gears</p>	<p>AXLES</p> <p>Manufacturer Bell</p> <p>Model 30T</p> <p>Differential High input controlled traction differential with spiral bevel gears</p> <p>Final Drive Outboard heavy duty planetary on all axles</p>	<p>FRONT SUSPENSION</p> <p>Semi-independent, leading A-frame supported by hydro-pneumatic suspension struts</p> <p>Option: Electronically controlled adaptive suspension with ride height adjustment</p> <p>REAR SUSPENSION</p> <p>Pivoting walking beams with laminated rubber suspension blocks</p> <p>Option: Comfort Ride suspension walking beams, with two-stage sandwich block</p>	<p>ELECTRIC SYSTEM</p> <p>Voltage 24 V</p> <p>Battery Type Two AGM (Absorption Glass Mat) type</p> <p>Battery Capacity 2 X 75 Ah</p> <p>Alternator Rating 28V 80A</p>																								
	<p>BRAKING SYSTEM</p> <p>Service Brake Dual circuit, full hydraulic actuation wet disc brakes on front and middle axles. Wet brake oil is circulated through a filtration and cooling system.</p> <p>Maximum brake force: 330 kN (74 187 lbf)</p> <p>Park & Emergency Spring applied, air released driveline mounted disc</p> <p>Maximum brake force: 218 kN (49 008 lbf)</p> <p>Auxiliary Brake Jacobs Engine Brake®. Automatic retardation through electronic activation of wet brake system.</p> <p>Total Retardation Power Continuous: 442 kW (593 hp) Maximum: 854 kW (1 145 hp)</p>	<p>HYDRAULIC SYSTEM</p> <p>Full load sensing system serving the prioritised steering, body tipping and brake functions. A ground-driven, load sensing emergency steering pump is integrated into the main system.</p> <p>Pump Type Variable displacement load sensing piston</p> <p>Flow 330 L/min (87 gal/min)</p> <p>Pressure 315 bar (4 569 psi)</p> <p>Filter 5 microns</p>	<p>MAX VEHICLE SPEED</p> <table border="1"> <tr><td>1st</td><td>4 km/h</td><td>2,5 mph</td></tr> <tr><td>2nd</td><td>9 km/h</td><td>6 mph</td></tr> <tr><td>3rd</td><td>17 km/h</td><td>11 mph</td></tr> <tr><td>4th</td><td>23 km/h</td><td>14 mph</td></tr> <tr><td>5th</td><td>33 km/h</td><td>21 mph</td></tr> <tr><td>6th</td><td>44 km/h</td><td>27,3 mph</td></tr> <tr><td>7th</td><td>51 km/h</td><td>32 mph</td></tr> <tr><td>R</td><td>7 km/h</td><td>4 mph</td></tr> </table>	1st	4 km/h	2,5 mph	2nd	9 km/h	6 mph	3rd	17 km/h	11 mph	4th	23 km/h	14 mph	5th	33 km/h	21 mph	6th	44 km/h	27,3 mph	7th	51 km/h	32 mph	R	7 km/h	4 mph
1st	4 km/h	2,5 mph																									
2nd	9 km/h	6 mph																									
3rd	17 km/h	11 mph																									
4th	23 km/h	14 mph																									
5th	33 km/h	21 mph																									
6th	44 km/h	27,3 mph																									
7th	51 km/h	32 mph																									
R	7 km/h	4 mph																									
		<p>STEERING SYSTEM</p> <p>Double acting cylinders, with ground-driven emergency steering pump</p> <p>Lock to lock turns 5</p> <p>Steering Angle 42°</p>	<p>WATER TANK</p> <p>Tank capacity 38 000 Litres</p>																								
			<p>WATER TANKER PLUMBING</p> <p>Centrifugal water pump</p> <p>Rate of Flow 5 400 L/min</p> <p>Head 70 m</p>																								
			<p>CAB</p> <p>ROPS/FOPS certified 76 dBA internal sound level measured according to ISO 6396</p>																								

Load Capacity & Ground Pressure

OPERATING WEIGHTS		GROUND PRESSURE		LOAD CAPACITY	
UNLADEN		LADEN (No sinkage/Total Contact Area Method)			
	kg (lb)	29.5 R 25 (kPa/Psi)	875/65 R29 (kPa/Psi)		
Total	35 479 (78 218)	Front: 314 (45,5)	Front: 295 (42,8)	Rated Payload	38 000 litres
		Mid/Rear: 370 (53,7)	Mid/Rear: 331 (48)		(10 000 gallons)
LADEN		Calculation method used by competition			
	kg (lb)	29.5 R 25 (kPa/Psi)	875/65 R29 (kPa/Psi)		
Front	22 739 (50 131)	Front: 153 (22,2)	Front: 135 (19,6)		
Middle	27 115 (59 778)	Mid/Rear: 176 (25,5)	Mid/Rear: 154 (22,3)		
Rear	26 626 (58 700)				
Total	76 479 (168 607)				

Dimensions

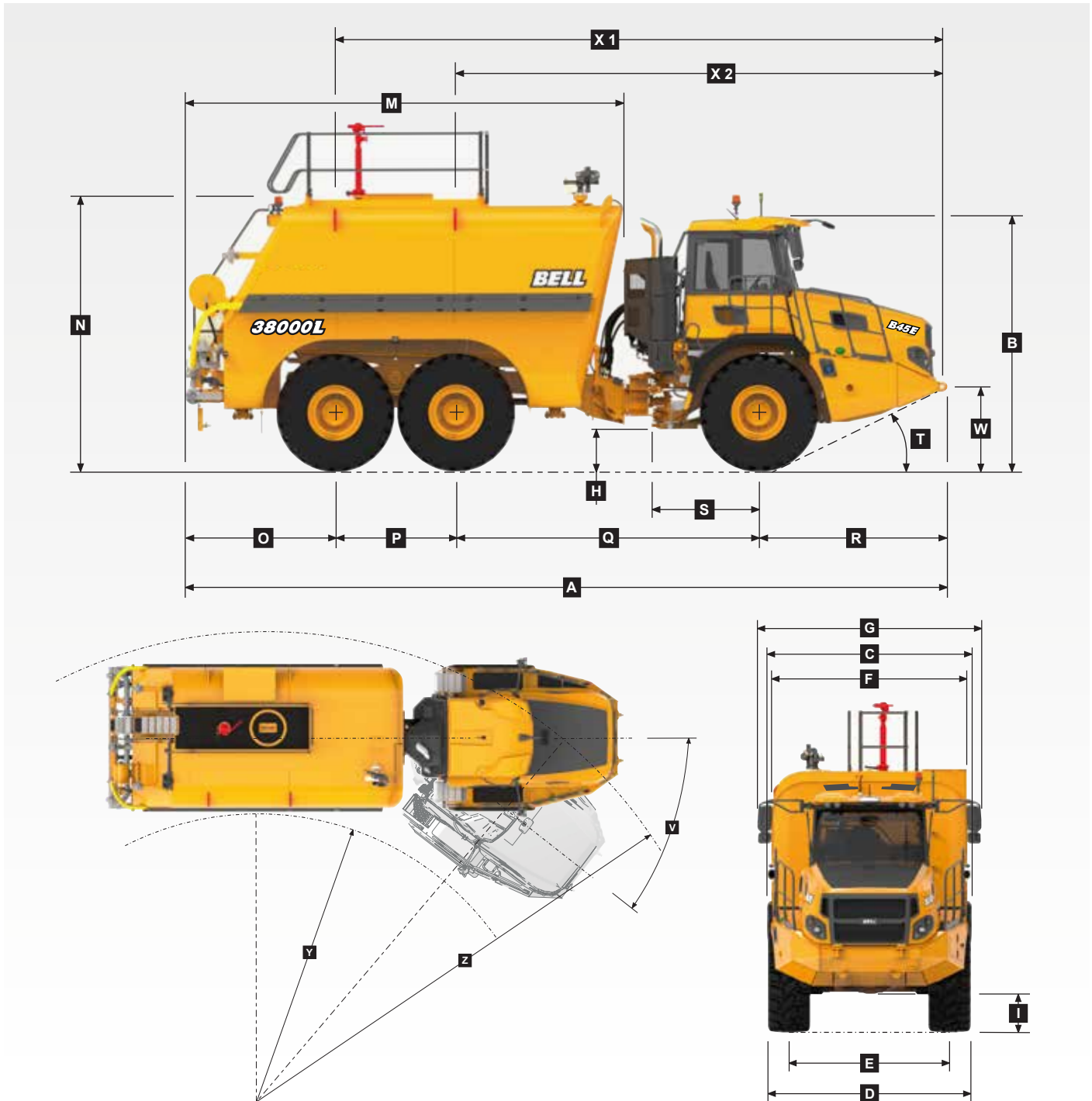

Machine Dimensions

A	Length - Transport Position	12 084 mm	(39 ft. 8 in.)	P	Mid Axle Centre to Rear Axle Centre	1 950 mm	(6 ft. 5 in.)
B	Height - Transport Position	3 802 mm	(12 ft. 6 in.)	Q	Mid Axle Centre to Front Axle Centre	4 438 mm	(14 ft. 7 in.)
C	Width over Mudguards	3 495 mm	(11 ft. 6 in.)	R	Front Axle Centre to Machine Front	3 253 mm	(10 ft. 8 in.)
D	Width over Tyres - 875/65 R29	3 656 mm	(11 ft. 12 in.)	S	Front Axle Centre to Artic Centre	1 558 mm	(5 ft. 1 in.)
D	Tyre Track Width - 29.5R25	3 487 mm	(11 ft. 5 in.)	T	Approach Angle	25°	
E	Tyre Track Width - 875/65 R29	2 773 mm	(9 ft. 1 in.)	V	Maximum Articulation Angle	45°	
E	Tyre Track Width - 29.5R25	2 725 mm	(8 ft. 11 in.)	W	Front Tie Down Height	1 282 mm	(4 ft. 2 in.)
F	Width over Tank / Bowser	3 379 mm	(11 ft. 1 in.)	X1	Tank Lifting Centres	10 023 mm	(32 ft. 10 in.)
G	Width over Mirrors - Operating Position	4 027 mm	(13 ft. 3 in.)	X2	Front Lifting Centres to Tank Lifting Centre	7 173 mm	(23 ft. 6 in.)
H	Ground Clearance - Artic	545 mm	(1 ft. 9 in.)	Y	Inner Turning Circle Radius - 875/65 R29	4 782 mm	(15 ft. 8 in.)
I	Ground Clearance - Front Axle	543 mm	(1 ft. 9 in.)	Y	Inner Turning Circle Radius - 29.5R25	4 866 mm	(15 ft. 12 in.)
M	Tank / Bowser Length	6 797 mm	(22 ft. 4 in.)	Z	Outer Turning Circle Radius - 875/65 R29	9 320 mm	(30 ft. 7 in.)
N	Maximum Tank Height	4 002 mm	(13 ft. 2 in.)	Z	Outer Turning Circle Radius - 29.5R25	9 235 mm	(30 ft. 4 in.)
O	Rear Axle Centre to Bowser / Tank Rear	2 443 mm	(8 ft. 0 in.)				

Gradeability/Rimpull

1. Determine tractive resistance by finding intersection of vehicle mass line and grade line. NOTE: 2% typical rolling resistance is already assumed in chart and grade line.
2. From this intersection, move straight right across charts until line intersects rimpull curve.
3. Read down from this point to determine maximum speed attained at that tractive resistance.

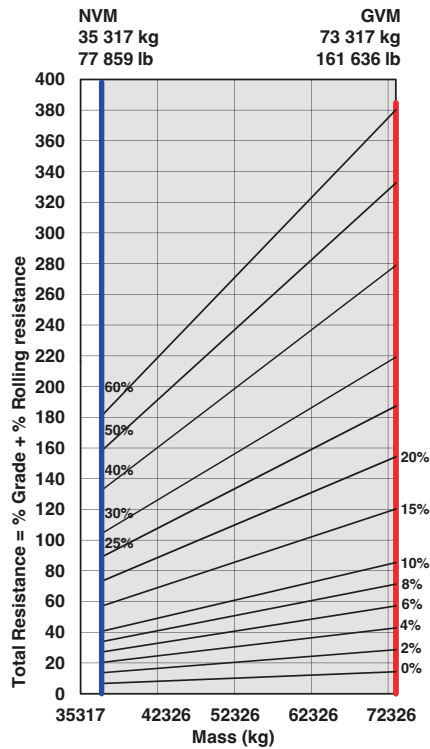

B45E 6x6 38 000 Ltr Water Tanker - Tractive Effort

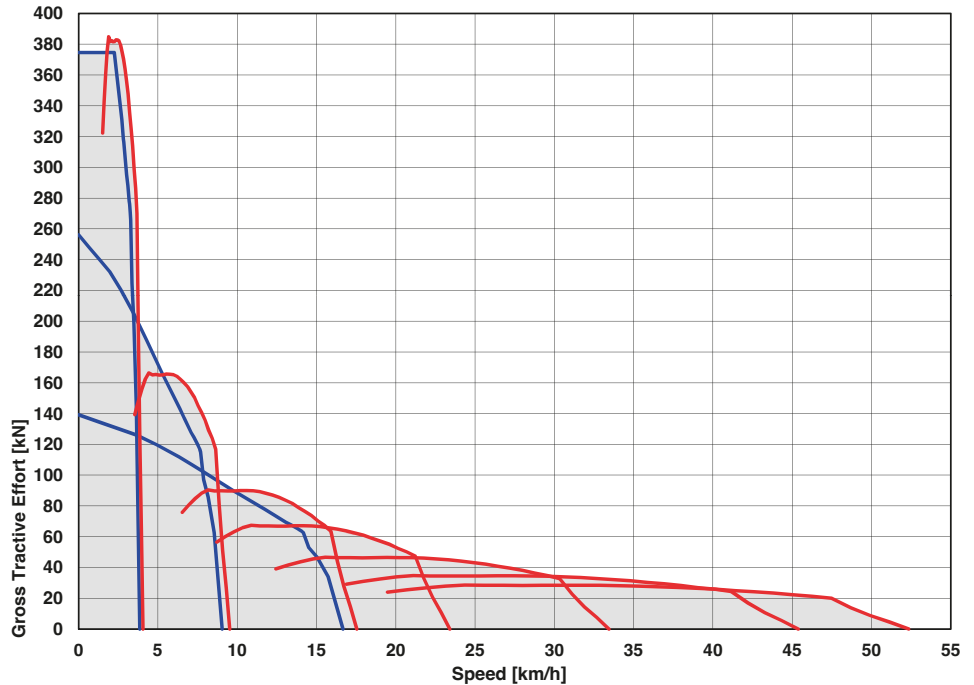

Retardation

1. Determine retardation force required by finding intersection of vehicle mass line.
2. From this intersection, move straight right across charts until line intersects the curve. NOTE: 2% typical rolling resistance is already assumed in chart.
3. Read down from this point to determine maximum speed.

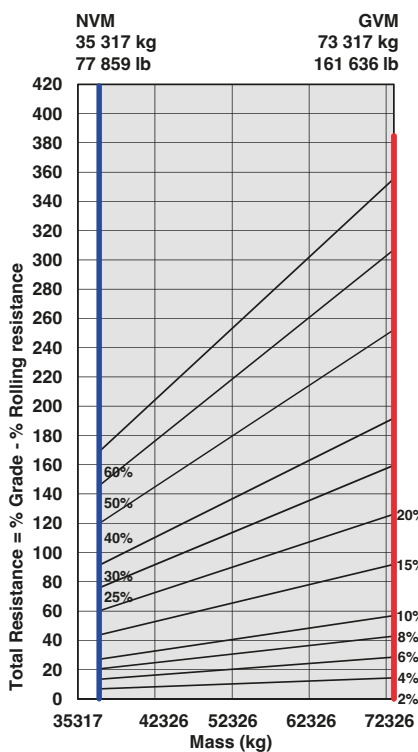

B45E 6x6 38 000 Ltr Water Tanker - Retardation

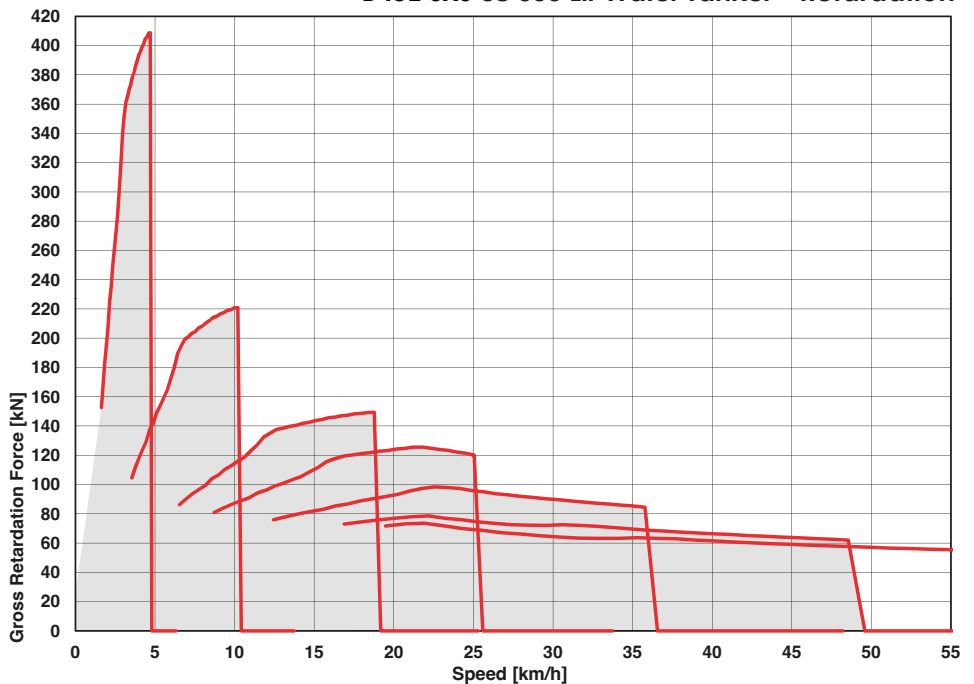

B50E 6x6 45 000 L Articulated Water Truck

ENGINE Manufacturer Mercedes Benz (MTU) Model OM473LA (MTU 6R 1500) Configuration Inline 6, turbocharged and intercooled Net Power 430 kW (577 hp) @ 1 600 rpm Gross Torque 2 850 Nm (2 102 lbf) @ 1 300 rpm Displacement 15,6 litres (952 cu.in) Auxiliary Brake Jacobs Engine Brake® Fuel Tank Capacity 630 litres (166 US gal) Certification OM473LA (MTU 6R 1500) is EU Stage IIIA / EPA Tier 3 emission level equivalent	TRANSFER CASE Manufacturer Kessler Model W2400 Layout Remote mounted Gear Layout Three in-line helical gears Output Differential Interaxle 29/71 proportional differential. Automatic inter-axle differential lock.	WHEELS Type Radial Earthmover Type 875/65 R 29 (29.5 R 25 optional)	PNEUMATIC SYSTEM Air drier with heater and integral unloader valve, serving park brake and auxiliary functions System Pressure 810 kPa (117 psi)																								
TRANSMISSION Manufacturer Allison Model 4800 ORS Configuration Fully automatic planetary transmission Layout Engine mounted Gear Layout Constant meshing planetary gears, clutch operated Gears 7 Forward, 1 reverse Clutch Type Hydraulically operated multi-disc Control Type Electronic Torque Control Hydrodynamic with lock-up in all gears	AXLES Manufacturer Bell Model 30T Differential High input controlled traction differential with spiral bevel gears Final Drive Outboard heavy duty planetary on all axles	FRONT SUSPENSION Semi-independent, leading A-frame supported by hydro-pneumatic suspension struts Option: Electronically controlled adaptive suspension with ride height adjustment REAR SUSPENSION Pivoting walking beams with laminated rubber suspension blocks Option: Comfort Ride suspension walking beams, with two-stage sandwich block	ELECTRIC SYSTEM Voltage 24 V Battery Type Two AGM (Absorption Glass Mat) type Battery Capacity 2 X 75 Ah Alternator Rating 28V 80A																								
	BRAKING SYSTEM Service Brake Dual circuit, full hydraulic actuation wet disc brakes on front and middle axles. Wet brake oil is circulated through a filtration and cooling system. Maximum brake force: 458 kN (102 962 lbf) Park & Emergency Spring applied, air released driveline mounted disc Maximum brake force: 215.5 kN (48 446 lbf) Auxiliary Brake Jacobs Engine Brake®. Automatic retardation through electronic activation of wet brake system. Total Retardation Power Continuous: 546 kW (732 hp) Maximum: 963 kW (1 291 hp)	HYDRAULIC SYSTEM Full load sensing system serving the prioritised steering, body tipping and brake functions. A ground-driven, load sensing emergency steering pump is integrated into the main system. Pump Type Variable displacement load sensing piston Flow 330 L/min (87 gal/min) Pressure 315 bar (4 569 psi) Filter 5 microns	MAX VEHICLE SPEED <table border="1"> <tr><td>1st</td><td>4 km/h</td><td>2,5 mph</td></tr> <tr><td>2nd</td><td>9 km/h</td><td>6 mph</td></tr> <tr><td>3rd</td><td>17 km/h</td><td>11 mph</td></tr> <tr><td>4th</td><td>23 km/h</td><td>14 mph</td></tr> <tr><td>5th</td><td>33 km/h</td><td>21 mph</td></tr> <tr><td>6th</td><td>44 km/h</td><td>27,3 mph</td></tr> <tr><td>7th</td><td>51 km/h</td><td>32 mph</td></tr> <tr><td>R</td><td>7 km/h</td><td>4 mph</td></tr> </table>	1st	4 km/h	2,5 mph	2nd	9 km/h	6 mph	3rd	17 km/h	11 mph	4th	23 km/h	14 mph	5th	33 km/h	21 mph	6th	44 km/h	27,3 mph	7th	51 km/h	32 mph	R	7 km/h	4 mph
1st	4 km/h	2,5 mph																									
2nd	9 km/h	6 mph																									
3rd	17 km/h	11 mph																									
4th	23 km/h	14 mph																									
5th	33 km/h	21 mph																									
6th	44 km/h	27,3 mph																									
7th	51 km/h	32 mph																									
R	7 km/h	4 mph																									
		STEERING SYSTEM Double acting cylinders, with ground-driven emergency steering pump Lock to lock turns 4,9 Steering Angle 42°	WATER TANK Tank capacity 45 000 Litres WATER TANKER PLUMBING Centrifugal water pump Rate of Flow 5 400 L/min Head 70 m																								
			CAB ROPS/FOPS certified 76 dBA internal sound level measured according to ISO 6396																								

Load Capacity & Ground Pressure

OPERATING WEIGHTS		GROUND PRESSURE		LOAD CAPACITY	
UNLADEN		LADEN (No sinkage/Total Contact Area Method)			
	kg (lb)	875/65 R29	kPa (Psi)		
Total	38 287 (84 408)	Front	297 (43,1)	Rated Payload	45 000 litres (11 900 gallons)
		Middle/Rear	366 (53,1)		
LADEN					
	kg (lb)	29.5 R 25	kPa (Psi)		
Front	24 034 (52 986)	Front	339 (49,2)		
Middle	29 879 (65 872)	Middle	381 (55,3)		
Rear	29 774 (65 640)				
Total	83 687 (184 498)				

Dimensions

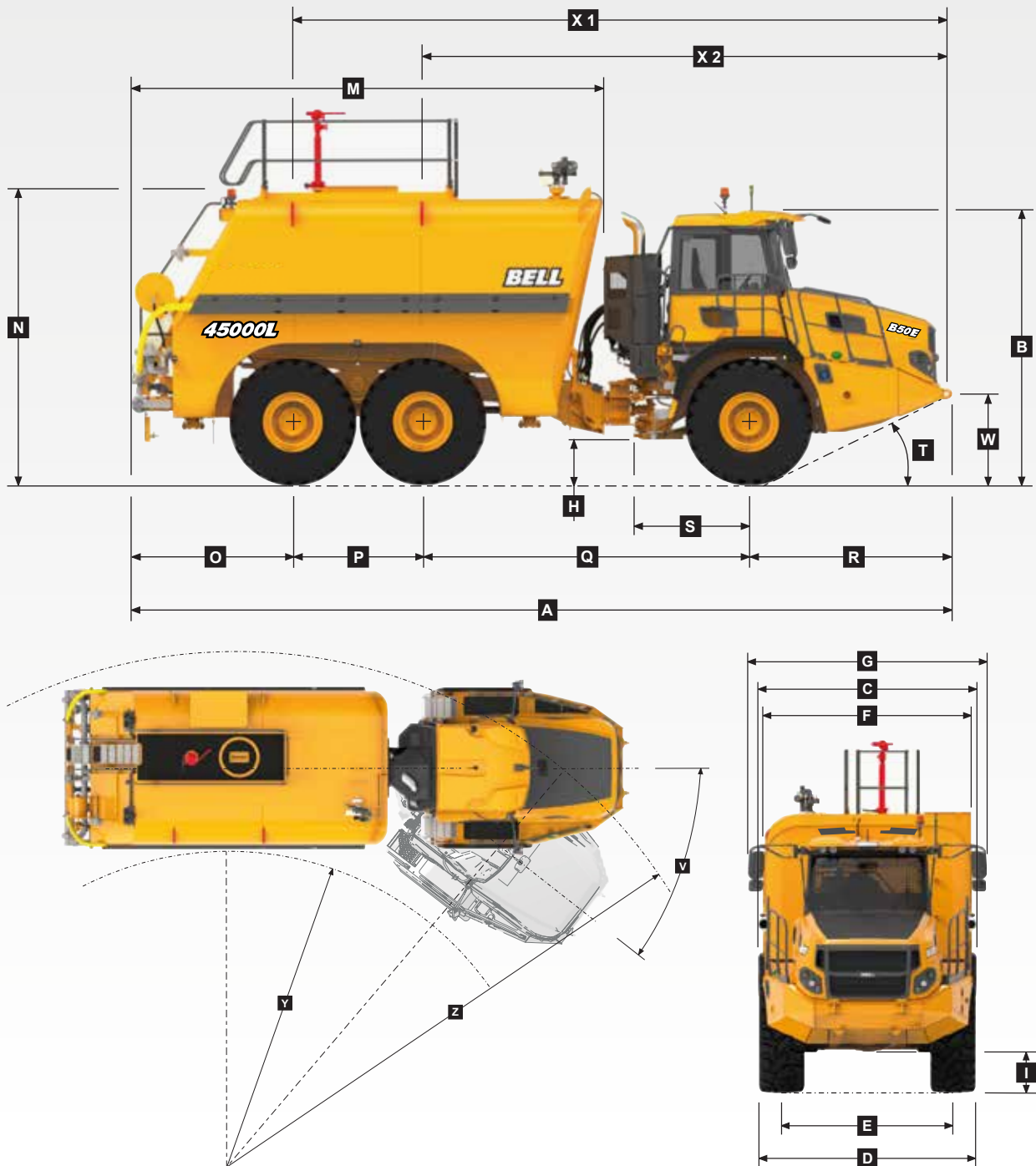

Machine Dimensions

A	Length - Transport Position	12 279 mm	(40 ft. 3 in.)	O	Rear Axle Centre to Bowser / Tank Rear	2 543 mm	(8 ft. 4 in.)
B	Height - Transport Position	3 820 mm	(12 ft. 6 in.)	P	Mid Axle Centre to Rear Axle Centre	1 950 mm	(6 ft. 5 in.)
C	Width over Mudguards	3 790 mm	(12 ft. 5 in.)	Q	Mid Axle Centre to Front Axle Centre	4 438 mm	(14 ft. 7 in.)
D	Width over Tyres - 875/65 R29	3 832 mm	(12 ft. 7 in.)	R	Front Axle Centre to Machine Front	3 351 mm	(11 ft. 0 in.)
D	Tyre Track Width - 29.5R25	3 714 mm	(12 ft. 2 in.)	S	Front Axle Centre to Artic Centre	1 558 mm	(5 ft. 1 in.)
E	Tyre Track Width - 875/65 R29	2 949 mm	(9 ft. 8 in.)	T	Approach Angle	23°	
E	Tyre Track Width - 29.5R25	2 952 mm	(9 ft. 8 in.)	V	Maximum Articulation Angle	42°	
F	Width over Tank / Bowser	3 699 mm	(12 ft. 2 in.)	W	Front Tie Down Height	1 269 mm	(4 ft. 2 in.)
F	Width over Tank / Bowser (with hose)	3 849 mm	(12 ft. 8 in.)	X1	Tank Lifting Centres	10 218 mm	(33 ft. 6 in.)
G	Width over Mirrors - Operating Position	4 027 mm	(13 ft. 3 in.)	X2	Front Lifting Centres to Tank Lifting Centre	7 310 mm	(24 ft. 0 in.)
H	Ground Clearance - Artic	558 mm	(1 ft. 9 in.)	Y	Inner Turning Circle Radius - 875/65 R29	4 694 mm	(15 ft. 5 in.)
I	Ground Clearance - Front Axle	555 mm	(1 ft. 9 in.)	Y	Inner Turning Circle Radius - 29.5R25	4 753 mm	(15 ft. 7 in.)
M	Tank / Bowser Length	6 877 mm	(22 ft. 7 in.)	Z	Outer Turning Circle Radius - 875/65 R29	9 408 mm	(30 ft. 10 in.)
N	Maximum Tank Height	4 137 mm	(13 ft. 7 in.)	Z	Outer Turning Circle Radius - 29.5R25	9 349 mm	(30 ft. 8 in.)

Gradeability/Rimpull

1. Determine tractive resistance by finding intersection of vehicle mass line and grade line. NOTE: 2% typical rolling resistance is already assumed in chart and grade line.
2. From this intersection, move straight right across charts until line intersects rimpull curve.
3. Read down from this point to determine maximum speed attained at that tractive resistance.

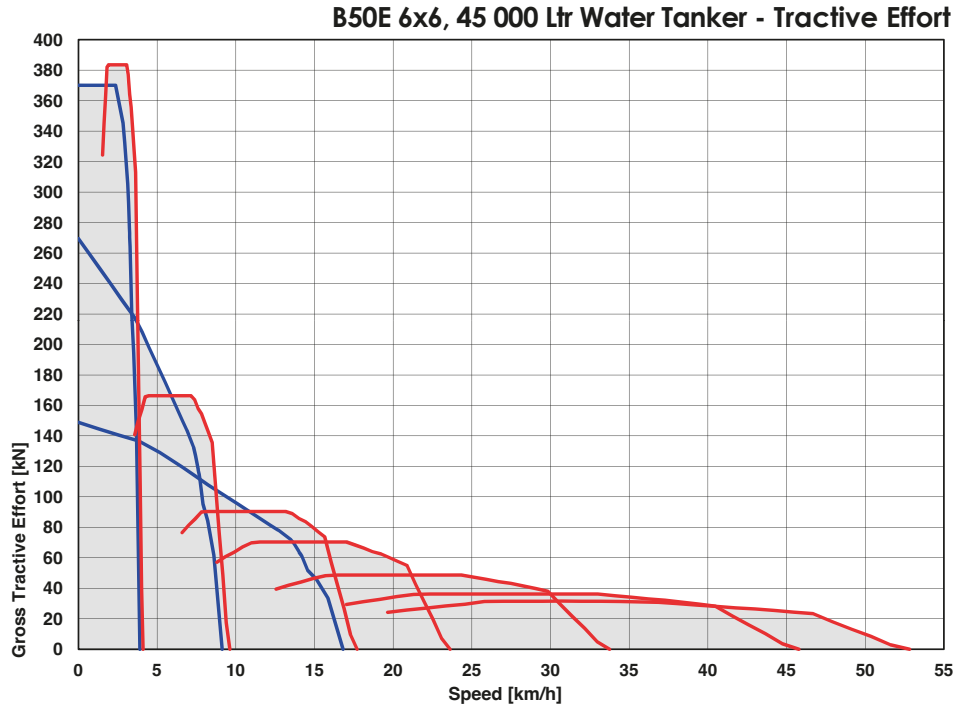
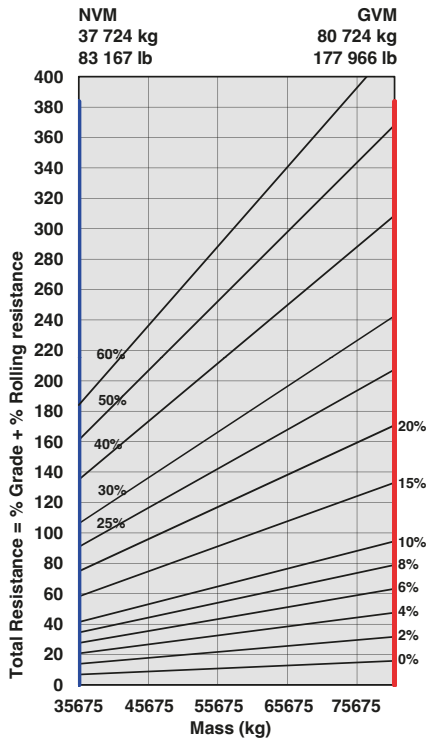

Retardation

1. Determine retardation force required by finding intersection of vehicle mass line.
2. From this intersection, move straight right across charts until line intersects the curve. NOTE: 2% typical rolling resistance is already assumed in chart.
3. Read down from this point to determine maximum speed.

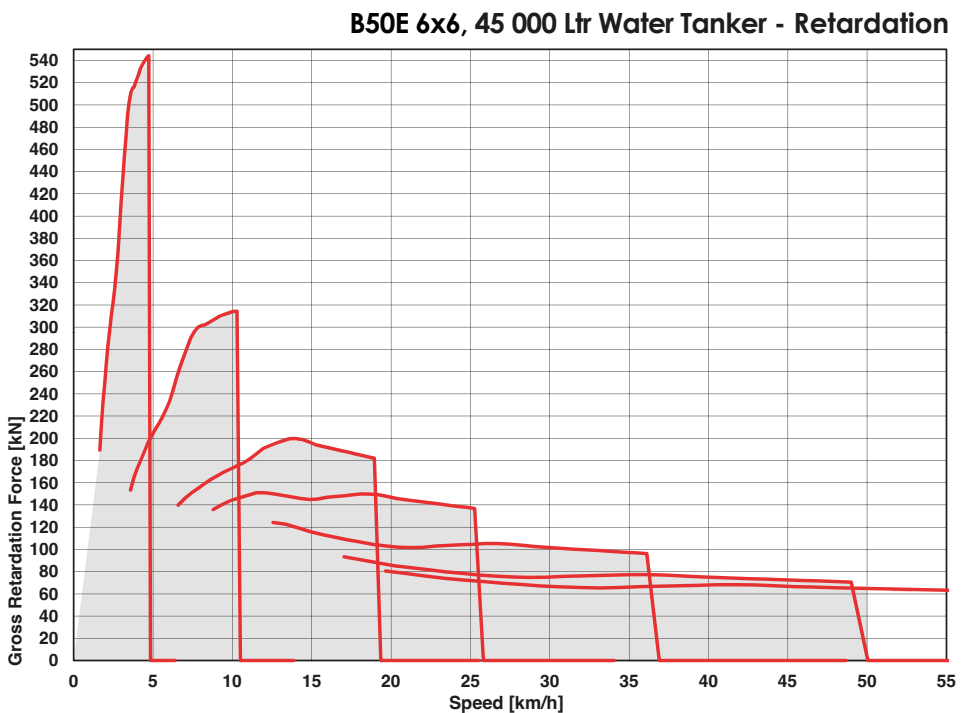
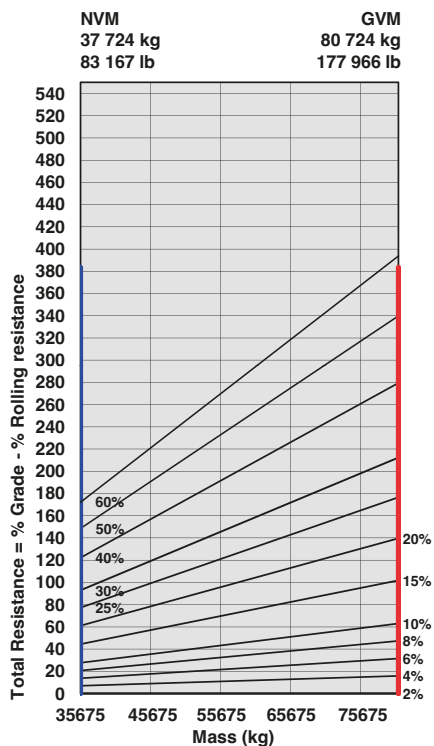

B60E 4x4 50 000 L Articulated Water Truck

ENGINE

Manufacturer
Mercedes Benz (MTU)

Model
OM473LA (MTU 6R 1500)

Configuration
Inline 6, turbocharged and intercooled

Maximum Net Power
430 kW (577 hp) at 1 600 rpm in accordance with UN ECE R120

Gross Torque
2 850 Nm (2 102 lbf) @ 1 300 rpm

Displacement
15,6 litres (952 cu.in)

Auxiliary Brake
Jacobs Engine Brake®

Fuel Tank Capacity
630 litres (1 66 US gal)

Certification
OM473LA (MTU 6R 1500) is EU Stage IIIA emission level equivalent.

TRANSMISSION

Manufacturer
Allison

Model
4800 ORS

Configuration
Fully automatic planetary transmission

Layout
Engine mounted

Gear Layout
Constant meshing planetary gears, clutch operated

Gears
7 Forward, 1 Reverse

Clutch Type
Hydraulically operated multi-disc

Control Type
Electronic

Torque Control
Hydrodynamic with lock-up in all gears

TRANSFER CASE

Manufacturer
Kessler

Series
W2400

Layout
Remote mounted

Gear Layout
Three in-line helical gears

Output Differential
Interaxle 29/71 proportional differential. Automatic inter-axle differential lock.

AXLES

Manufacturer
Front - Bell
Rear - Kessler

Model
Front: 30T
Rear: 71T

Differential
Front: High input controlled traction differential with spiral bevel gears.
Rear: Centre input open differential with spiral bevel gears.

Final Drive
Outboard heavy duty planetary on all axles

BRAKING SYSTEM

Service Brake
Dual circuit, full hydraulic actuation wet disc brakes on front and rear axles. Wet brake oil is circulated through a filtration and cooling system.

Maximum brake force:
446 kN (100 264 lbf)

Park & Emergency
Spring applied, air released driveline mounted disc

Maximum brake force:
341 kN (76 659 lbf)

Auxiliary Brake
Automatic Jacobs Engine Brake®. Automatic retardation through electronic activation of wet brake system.

Total Retardation Power
Continuous: 574 kW (770 hp)
Maximum: 983 kW (1 318 hp)

WHEELS

Type
Radial Earthmover

Tyre
Front: 875/65 R29
Rear: 24.00 R 35 Dual

FRONT SUSPENSION

Semi-independent, leading A-frame supported by hydro-pneumatic suspension struts. Active dual springrate Comfort Ride suspension, including height control.

REAR SUSPENSION

Trailing arm cradle supported by hydro-pneumatic suspension struts, with an additional lateral stabiliser.

HYDRAULIC SYSTEM

Full load sensing system serving the prioritized steering, body tipping, suspension and brake functions. A ground-driven, load sensing emergency steering pump is integrated into the main system.

Pump Type
Variable displacement load sensing piston

Flow
300 L/min (79 gal/min)

Pressure
280 Bar (4 060 psi)

Filter
5 microns

STEERING SYSTEM

Double acting cylinders, with ground-driven emergency steering pump.

Lock to lock turns
5,5

Steering Angle
42°

DUMPING SYSTEM

Two double-acting, two stage telescopic, dump cylinders

Raise Time
18 seconds

Lowering Time
16,5 seconds

Tipping Angle
55 deg standard, or any lower angle programmable

PNEUMATIC SYSTEM

Air drier with heater and integral unloader valve, serving park brake and auxiliary functions.

System Pressure
8,1 Bar (117 psi)

ELECTRICAL SYSTEM

Voltage
24 V

Battery Type
Two AGM (Absorption Glass Mat) type

Battery Capacity
2 X 75 Ah

Alternator Rating
28 V 100 A

MAX. VEHICLE SPEED

1st	4 km/h	2,5 mph
2nd	8 km/h	5,6 mph
3rd	16 km/h	10,6 mph
4th	21 km/h	13,7 mph
5th	30 km/h	20 mph
6th	41 km/h	27 mph
7th	47 km/h	32 mph
R	6 km/h	4 mph

WATER TANK

Tank capacity
50 000 Litres

WATER TANKER PLUMBING

Centrifugal water pump

Rate of Flow
5 400 L/min

Head
70 m

CAB

ROPS/FOPS certified 77 dBA internal sound pressure measured according to ISO 6396.

Load Capacity & Ground Pressure

OPERATING WEIGHTS		GROUND PRESSURE		LOAD CAPACITY	
UNLADEN		LADEN (No sinkage/Total Contact Area Method)			
	kg (lb)	875/65 R29	kPa (Psi)		
Total	45 367 (100 017)	Front	333 (48,2)	Rated Payload	50 000 litres (13 200 gallons)
LADEN		24.00 R35	kPa (Psi)		
	kg (lb)	Rear	478 (69,3)		
Front	26 842 (59 176)				
Rear	73 525 (165 095)				
Total	100 367 (221 271)				

Dimensions

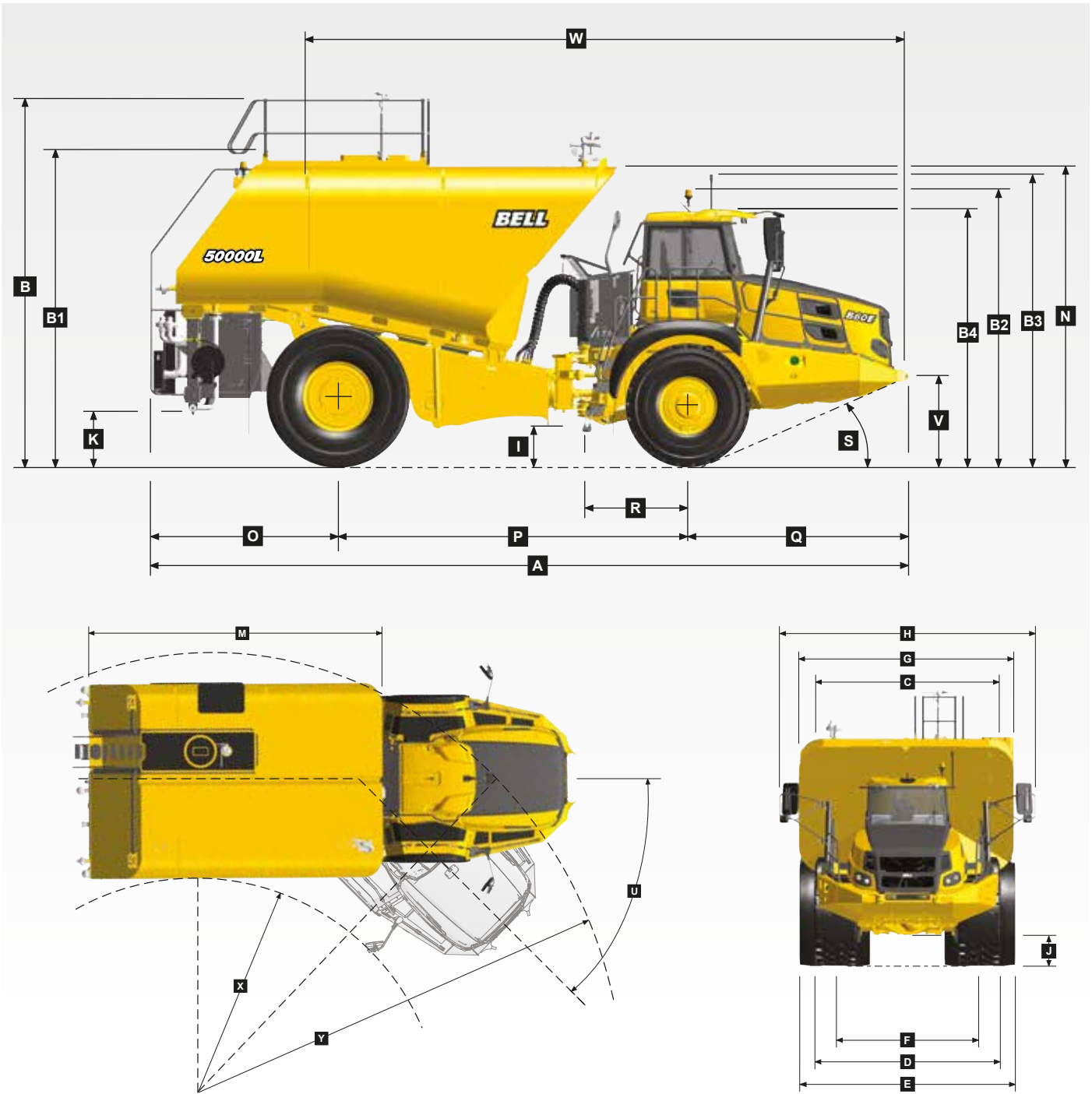

Machine Dimensions

A	Length - Transport Position	11 469 mm	(37 ft. 6 in.)	J	Ground Clearance - Front Axle	554 mm	(21.81 in.)
B	Height - Handrails Raised	5 545 mm	(18 ft. 2 in.)	K	Ground Clearance - Dribble Bar	818 mm	(32 in.)
B1	Height - Transport Position Handrails Down	4 765 mm	(15 ft. 7 in.)	M	Tank / Bowser Length	6 672 mm	(21 ft. 9 in.)
B2	Height - Rotating Beacon	4 112 mm	(13 ft. 6 in.)	N	Platform	4 515 mm	(14 ft. 9 in.)
B3	Height - Load Light	4 335 mm	(14 ft. 3 in.)	O	Rear Axle Centre to Tank Rear / Bowser	2 836 mm	(9 ft. 4 in.)
B4	Height - Cab	3 813 mm	(12 ft. 6 in.)	P	Rear Axle Centre to Front Axle Centre	5 285 mm	(17 ft. 4 in.)
C	Width over Mudguards	3 790 mm	(12 ft. 5 in.)	Q	Front Axle Centre to Machine Front	3 352 mm	(10 ft. 12 in.)
D	Width over Tyres - Front 875/65 R29	3 832 mm	(12 ft. 7 in.)	R	Front Axle Centre to Artic Centre	1 558 mm	(5 ft. 1 in.)
E	Tyre Track Width - Rear 24.00 R35	4 444 mm	(14 ft. 7 in.)	S	Approach Angle	22°	
F	Tyre Track Width - Front	2 949 mm	(9 ft. 8 in.)	T	Maximum Articulation Angle	42°	
F	Tyre Track Width - Rear	2 992 mm	(9 ft. 10 in.)	V	Front Tie Down Height	1 263 mm	(4 ft. 2 in.)
G	Width over Tank / Bowser	4 433 mm	(14 ft. 6 in.)	W	Machine Lifting Centres	9 064 mm	(29 ft. 8 in.)
H	Width over Mirrors - Operating Position	5 283 mm	(17 ft. 4 in.)	X	Inner Turning Circle Radius	4 246 mm	(13 ft. 11 in.)
I	Ground Clearance - Artic	561 mm	(22.09 in.)	Y	Outer Turning Circle Radius	9 216 mm	(30 ft. 3 in.)

Gradeability/Rimpull

1. Determine tractive resistance by finding intersection of vehicle mass line and grade line. NOTE: 2% typical rolling resistance is already assumed in chart and grade line.
2. From this intersection, move straight right across charts until line intersects rimpull curve.
3. Read down from this point to determine maximum speed attained at that tractive resistance.

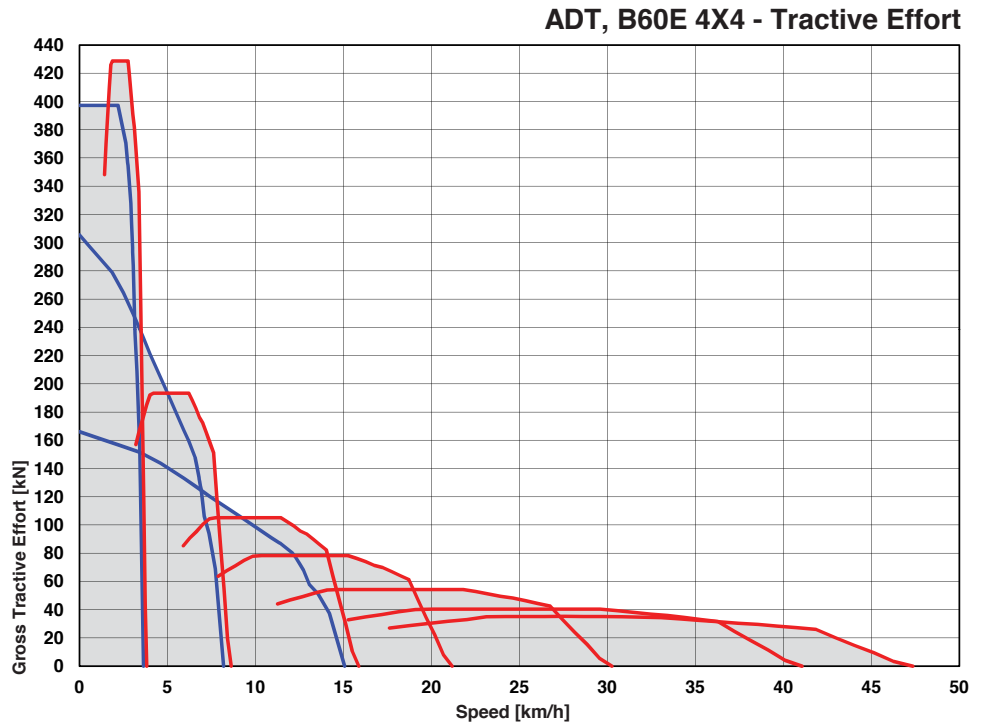
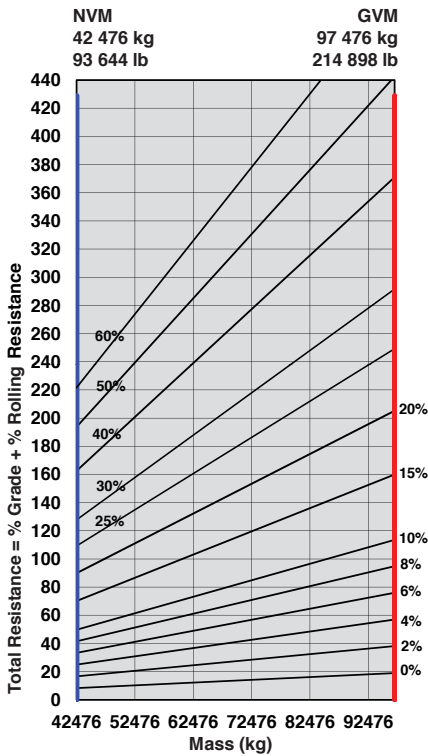

Retardation

1. Determine retardation force required by finding intersection of vehicle mass line.
2. From this intersection, move straight right across charts until line intersects the curve. NOTE: 2% typical rolling resistance is already assumed in chart.
3. Read down from this point to determine maximum speed.

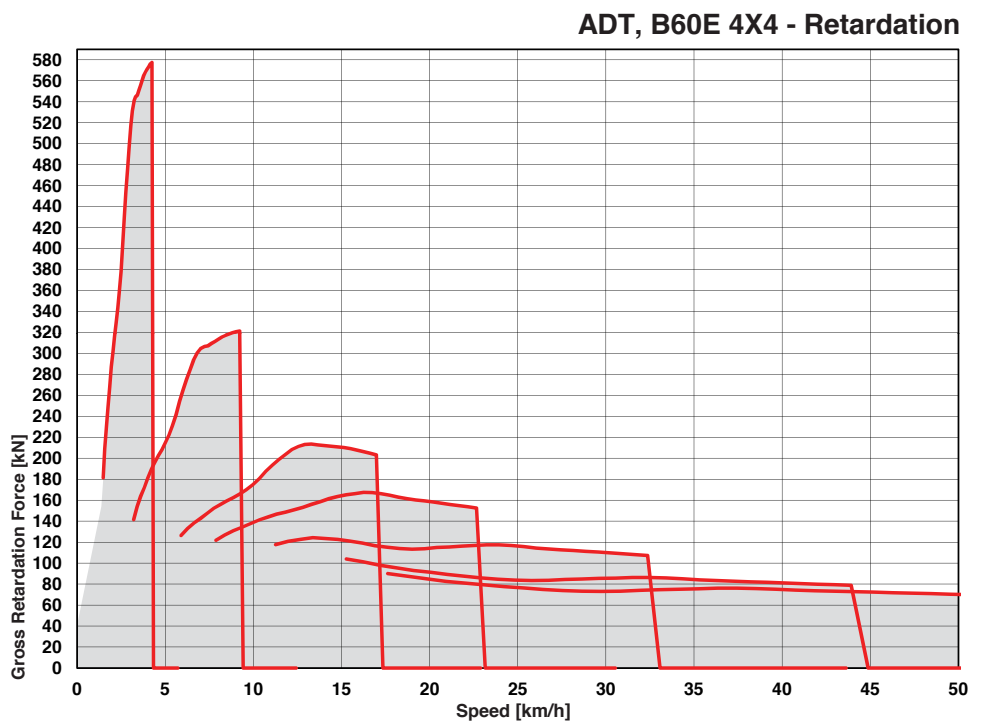
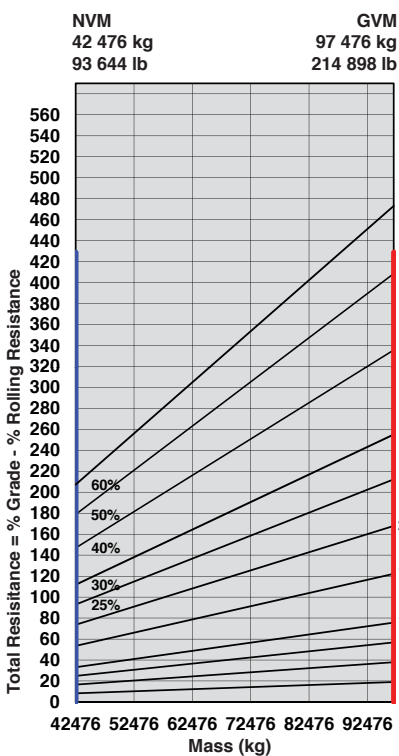



BATTER SPRAYS

- Two additional spray valves that expand the spray patterns reach on the sides of the tank
- Remotely activated from inside the cab



HOSE REEL

- 30m hose reel
- 1.5" adjustable fog/stream nozzle
- Spring retractable

DRIBBLE BAR

- Gravity fed dribble bar
- Remotely activated from inside the cab
- Even spread pattern covering the width of the vehicle



PENETRATION SPRAY BARS

- Available with nozzles or holes
- Remotely activated from inside the cab
- Pressurised by the pump to create a jet of water



REMOTE WATER CANNON

- Adjustable fog/stream pattern
- A variety of flow settings between 250 and 700 GPM
- Remotely controlled via a joystick inside the cab
- High quality components built to last in heavy duty applications

MANUAL WATER CANNON

- Long range spray nozzle
- High quality components built to last in heavy duty applications



16 000 L	18 000 L	23 000 L	27 000 L	35 000 L	38 000 L	45 000 L	
							ENGINE
●	●	●	●	●	●	●	Engine valve brake and exhaust brake
●	●	●	●	●	●	●	Dual element air cleaner with dust ejector valve
●	●	●	●	●	●	●	Precleaner with auto dust scavenging
●	●	●	●	●	●	●	Water separator
●	●	●	●	●	●	●	Serpentine drive belt with automatic tensioner
▲	▲	▲	▲	●	●	●	Provision for fast fill
▲	▲	▲	▲	●	●	●	Wet-sleeve cylinder liners
							COOLING
●	●	●	●	●	●	●	Crank-shaft mounted viscous-drive fan
●	●	●	●	●	●	●	Fan guard
							PNEUMATIC SYSTEM
●	●	●	●	●	●	●	Engine-mounted compressor
●	●	●	●	●	●	●	Air drier with heater
●	●	●	●	●	●	●	Integral unloader valve
							ELECTRICAL SYSTEM
●	●	●	●	●	●	●	Battery disconnect
●	●	●	●	●	●	●	Drive lights
●	●	●	●	●	●	●	Air horn
●	●	●	●	●	●	●	Reverse alarm
●	▲	▲	▲	▲	▲	▲	White noise reverse alarm
●	●	●	●	●	●	●	Rotating beacon
●	●	●	●	●	●	●	Pitch roll sensor
▲	▲	▲	▲	▲	▲	▲	LED drive lights
▲	▲	▲	▲	●	●	●	Halogen artic reverse light
▲	▲	▲	▲	▲	▲	▲	LED artic reverse light
●	●	●	●	●	●	●	LED reverse light
							STEERING SYSTEM
●	●	●	●	●	●	●	Uni-directional ground-driven secondary steering pump
▲	▲	▲	▲	▲	▲	▲	Bi-directional ground-driven secondary steering pump
							CAB
●	●	●	●	●	●	●	ROPS/FOPS certification
●	●	●	●	●	●	●	Tilt cab
●	●	●	●	●	●	●	Gas strut-supported door
●	●	●	●	●	●	●	HVAC Climate control system
●	●	●	●	●	●	●	AM/FM radio/CD player + USB
●	●	●	●	●	●	●	Rear window guard
●	●	●	●	●	●	●	Wiper/washer with intermittent control
●	●	●	●	●	●	●	Tilt and telescoping steering wheel
●	●	●	●	●	●	●	Centre-mount air-suspension seat
●	●	●	●	●	●	●	Halogen work lights
▲	▲	▲	▲	▲	▲	▲	LED work lights
▲	▲	▲	▲	▲	▲	▲	Rotating beacon: seat belt installation
▲	▲	▲	▲	▲	▲	▲	Remote engine and machine isolation
●	●	●	●	●	●	●	Remote battery jump start
●	●	▲	▲	●	●	●	High visibility mirrors
●	●	●	●	●	●	●	Retractable 3-point seat belt
●	●	●	●	●	●	●	Foldaway trainer seat with retractable seat belt
							CAB (continued)
●	●	●	●	●	●	●	12-volt power outlet
●	●	●	●	●	●	●	Cup holder
●	●	●	●	●	●	●	Cooled/heated lunch box
●	●	●	●	●	●	●	Utility bin (removable)
●	●	●	●	●	●	●	Manually adjustable mirrors
▲	▲	▲	▲	▲	▲	▲	Electric adjustable & heated mirrors
●	●	●	●	●	●	●	Deluxe 10" colour LCD: Speedometer / Fuel gauge / Transmission oil temperature gauge / Engine coolant temperature gauge / LED function/warning indicators and audible alarm / Transmission gear selection / Tachometer / Battery voltage / Hour meter / Odometer / Fuel consumption / Trip timer / Trip distance / Metric/English units / Service codes/diagnostics
●	●	●	●	●	●	●	Backlit sealed switch module functions with: Wiper control / Lights / Heated mirrors / Retarding aggressiveness / Transfer case differential lock / Transmission gear hold / Airconditioner/ Heater controls / Preselected Speed Control
●	●	●	●	●	●	●	Backlit Plumbing sealed switch module functions with: Battery / Spray / Pulse / Tank fill / Hose reel / Pump / Dribble bar
							PLUMBING
●	●	●	●	●	●	●	Dribble bar
●	●	●	●	●	●	●	1 800 lpm 50 m head pump
▲	▲	▲	▲	●	●	●	5 400 lpm 70 m head pump*
▲	▲	▲	▲	▲	▲	▲	Pressurised dribble bar system with nozzles
●	●	●	●	●	●	●	Spray valves (in-cab activation)
●	●	●	●	●	●	●	Batter spray valves
●	●	●	●	●	●	●	Fold down top rails
▲	▲	▲	▲	▲	▲	▲	Suction pipe for filling from dam
●	●	●	●	●	●	●	Step ladder access
▲	▲	▲	▲	▲	▲	▲	Inspection access
▲	▲	▲	▲	▲	▲	▲	Manual water canon
▲	▲	▲	▲	▲	▲	▲	Remote control water canon
▲	▲	▲	▲	▲	▲	▲	Hose reel
							OTHER
●	●	●	●	●	●	●	20.5 R 25 Radial earthmover tyres
▲	●	●	●	●	●	●	23.5 R 25 tyres
●	●	●	●	●	●	●	620/75 R26 tyres
●	●	●	●	●	●	▲	29.5 R 25 Radial Earthmover tyres
●	●	●	●	●	▲	●	875/65 R 29 Radial Earthmover tyres
●	●	●	●	●	●	●	Remote grease banks
▲	▲	▲	▲	▲	▲	▲	Automatic greasing
●	●	●	●	●	●	●	Cab peak
▲	▲	▲	▲	▲	▲	▲	High pressure hydraulic filter
▲	▲	▲	▲	▲	▲	▲	Fuel heater
●	●	●	●	●	●	●	Belly cover
▲	▲	▲	▲	▲	▲	▲	Handrails
▲	▲	▲	▲	▲	▲	▲	Remote transmission filter
●	▲	▲	▲	▲	▲	▲	Reverse camera

* (Option only): Larger centrifugal pump available if suction pipe option is not fitted.

FEATURES OF THE ARTICULATED WATER TRUCK

- **PRODUCTIVE:** Powerful built-for hauling ADT drivetrains are well matched for pulling and retarding heavy loads. Nitrogen over oil strut suspension smooths the ride for operator and machine.
- **ECONOMY:** Modern fuel efficient engine, lockup torque converter and planetary transmission deliver more work per unit of fuel used
 - **EASY TO OPERATE:** High quality cab is conducive to operator care. Simple to use controls and electronic interfaces protect the machine from accidental misuse.



35000L

All dimensions are shown in millimetres, unless otherwise stated between brackets. Under our policy of continuous improvement, we reserve the right to change technical data and design without prior notice. Photographs featured in this brochure may include optional equipment. Blu@dvan tage™ is a trademark of Bell Equipment Co. (PTY) Ltd AdBlue® is a registered trademark of VDA.



BELL INTERNATIONAL: +27 (0)35-907 9297

E-mail: connect@bellequipment.com • www.bellequipment.com

 Tel: +61 (0)8-9414-1751

 Tel: +27 (0)11-928-9700

 Tel: +49 (0)6631 / 91-13-0

 Tel: +44 (0)1283-712862

 Tel: +33 (0)5-55-89-23-56

 Tel: +1 (854) 855 7507

**Strong Reliable Machines
Strong Reliable Support**

BELL